

MAXIMUM USER'S

Instructions and recommendations

Installer

User

Maintenance technician



**VICTRIX ZEUS
SUPERIOR
25-30-35**

L.045260ENG



INDEX

Dear Customer.....	4
General Recommendations.....	5
Safety symbols used.....	6
Personal protective equipment	6
1 Boiler installation.....	7
1.1 Installation warnings.....	7
1.2 Main dimensions.....	12
1.3 Minimum installation distances	13
1.4 Antifreeze protection.....	13
1.5 Boiler connection group	14
1.6 Gas connection	15
1.7 Hydraulic connection	16
1.8 Electrical connection	16
1.9 Remote controls and room chrono-thermostats (Optional)	18
1.10 External temperature probe (Optional).....	19
1.11 Flow temperature probe (Optional).....	19
1.12 Temperature control setting.....	20
1.13 Immergas flue systems	21
1.14 Tables of resistance factors and equivalent lengths of “Green Range” flue system components.....	22
1.15 Outdoor installation in partially protected area	24
1.16 Concentric horizontal kit installation.....	26
1.17 Concentric vertical kit installation.....	27
1.18 Separator kit installation	30
1.19 C9 adaptor kit installation	32
1.20 C15 configuration concentric kit	35
1.21 Concentric kit C10 configuration (Ø 80/125).....	36
1.22 Configuration C10 - C12 separator kit (Ø 80/80).....	38
1.23 Ducting of flues or technical slots.....	41
1.24 Configuration type B, open chamber and fan assisted for indoors.....	42
1.25 Flue exhaust to flue/chimney.....	42
1.26 Flues, chimneys and chimney caps.....	42
1.27 Water treatment plant filling.....	43
1.28 System filling.....	44
1.29 Filling the condensate drain trap	45
1.30 Gas system start-up.....	45
1.31 Boiler start-up (Ignition)	45
1.32 Circulation pump	46
1.33 Kits available on request.....	49
1.34 Main components.....	50
2 Instructions for use and maintenance	51
2.1 General recommendations.....	51
2.2 Cleaning and maintenance.....	52
2.3 Control panel	53
2.4 Boiler use	53
2.5 Operating mode.....	54
2.6 Parameters and information menu.....	62
2.7 Fault and anomaly signals.....	68
2.8 Boiler switch-off.....	75
2.9 Restore central heating system pressure.....	75
2.10 Draining the system	75
2.11 Emptying the D.H.W. circuit.....	75

2.12	Storage tank draining.....	75
2.13	Antifreeze protection.....	76
2.14	Prolonged inactivity.....	76
2.15	Cleaning the case.....	76
2.16	Permanent shutdown.....	76
3	Instructions for maintenance and initial check.....	77
3.1	General recommendations.....	77
3.2	Initial check.....	77
3.3	Yearly appliance check and maintenance.....	78
3.4	Hydraulic diagram.....	80
3.5	Wiring diagram.....	81
3.6	Removable memory.....	82
3.7	Troubleshooting.....	82
3.8	Access reserved to service.....	83
3.9	Converting the boiler to other types of gas.....	83
3.10	Calibration type involving the replacement of a component.....	84
3.11	Complete calibration function.....	85
3.12	CO2 regulation.....	87
3.13	Quick calibration.....	88
3.14	Flue test.....	88
3.15	Parameters and information menu.....	90
3.16	Specific information for correct boiler installation in common pressurised flue systems (C10 - C12).....	103
3.17	Boiler coupling with wireless room probes.....	103
3.18	Automatic venting function.....	105
3.19	"Chimney sweep" function.....	105
3.20	Screed heater function.....	105
3.21	Pump anti-block function.....	106
3.22	Three-way anti-block system.....	106
3.23	Radiators antifreeze function.....	106
3.24	P.C.B. periodical self-check.....	106
3.25	Casing removal.....	107
4	Technical data.....	110
4.1	Variable heat output.....	110
4.2	Combustion parameters.....	113
4.3	Technical data table.....	115
4.4	Key for data nameplate.....	116
4.5	Technical parameters for combination boilers (in compliance with Regulation 813/2013).....	117
4.6	Product fiche (in compliance with Regulation 811/2013).....	120
4.7	Parameters for filling in the package fiche.....	123

Dear Customer

For assistance and routine maintenance, contact Authorised Technical Service Centres: they have original spare parts and are specifically trained directly by the manufacturer.

Congratulations for having chosen a top-quality Immergas product, able to assure well-being and safety for a long period of time. As an Immergas customer you can also count on a Qualified Authorised After-Sales Technical Assistance Centre, prepared and updated to guarantee constant efficiency of your appliance. Read the following pages carefully: you will be able to draw useful tips on the proper use of the device, compliance with which will confirm your satisfaction with the Immergas product.

The company **IMMERGAS S.p.A.**, with registered office in via Cisa Ligure 95 42041 Brescello (RE), declares that the design, manufacturing and after-sales assistance processes comply with the requirements of standard **UNIENISO 9001:2015**.

For further details on the product CE marking, request a copy of the Declaration of Conformity from the manufacturer, specifying the appliance model and the language of the country.

The manufacturer declines all liability due to printing or transcription errors, reserving the right to make any modifications to its technical and commercial documents without forewarning.



GENERAL RECOMMENDATIONS

This book contains important information for the:

Installer (section 1);

User (section 2);

Maintenance Technician (section 3).

- The user must carefully read the instructions in the specific section (section 2).
 - The user must limit operations on the appliance only to those explicitly allowed in the specific section.
 - The appliance must be installed by qualified and professionally trained personnel.
 - The instruction booklet is an integral and essential part of the product and must be given to the new user in the case of transfer or succession of ownership.
 - It must be stored with care and consulted carefully, as all of the warnings provide important safety indications for installation, use and maintenance stages.
 - In compliance with the legislation in force, the systems must be designed by qualified professionals, within the dimensional limits established by the Law. Installation and maintenance must be performed in compliance with the regulations in force, according to the manufacturer's instructions and by professionally qualified staff, meaning staff with specific technical skills in the plant sector, as provided for by Law.
 - Improper installation or assembly of the Immergas device and/or components, accessories, kits and devices can cause unexpected problems for people, animals and objects. Read the instructions provided with the product carefully to ensure proper installation.
 - This instructions manual provides technical information for installing Immergas products. As for the other issues related to the installation of products (e.g. safety at the workplace, environmental protection, accident prevention), it is necessary to comply with the provisions of the standards in force and the principles of good practice.
 - All Immergas products are protected with suitable transport packaging.
 - The material must be stored in a dry place protected from the weather.
 - Damaged products must not be installed.
 - Maintenance must be carried out by skilled technical staff. For example, the Authorised Service Centre that represents a guarantee of qualifications and professionalism.
 - The appliance must only be destined for the use for which it has been expressly declared. Any other use will be considered improper and therefore potentially dangerous.
 - If errors occur during installation, operation and maintenance, due to non-compliance with technical laws in force, standards or instructions contained in this booklet (or however supplied by the manufacturer), the manufacturer is excluded from any contractual and extra-contractual liability for any damages and the device warranty is invalidated.
 - In the event of malfunctions, faults or incorrect operation, turn the appliance off and contact an authorised company (e.g. the Authorised Technical Assistance Centre, which has specifically trained staff and original spare parts). Do not attempt to modify or repair the appliance alone.
-

SAFETY SYMBOLS USED



GENERIC HAZARD

Strictly follow all of the indications next to the pictogram. Failure to follow the indications can generate hazard situations resulting in possible harm to the health of the operator and user in general, and/or property damage.



ELECTRICAL HAZARD

Strictly follow all of the indications next to the pictogram. The symbol indicates the appliance's electrical components or, in this manual, identifies actions that can cause an electrical hazard.



MOVING PARTS

The symbol indicates the appliance's moving components that can cause hazards.



DANGER OF HOT SURFACES

The symbol indicates the appliance's very hot components that can cause burns.



WARNINGS

Strictly follow all of the indications next to the pictogram. Failure to follow the indications can generate hazard situations resulting in possible minor injuries to the health of both the operator and the user in general, and/or slight material damage.



ATTENTION

Read and understand the instructions of the appliance before carrying out any operation, carefully following the instructions given. Failure to observe the instructions may result in malfunction of the unit.



INFORMATION

Indicates useful tips or additional information.



EARTH TERMINAL CONNECTION

The symbol identifies the appliance's earth terminal connection point.



DISPOSAL WARNING

The user must not dispose of the appliance at the end of its service life as municipal waste, but send it to appropriate collection centres.

PERSONAL PROTECTIVE EQUIPMENT



SAFETY GLOVES



EYE PROTECTION



SAFETY FOOTWEAR

1 BOILER INSTALLATION

1.1 INSTALLATION WARNINGS



Operators who install and service the appliance must wear the personal protective equipment required by applicable law.



This boiler has been designed for wall-mounted installation only; for central heating and production of domestic hot water for domestic use and similar purposes.



The place of installation of the appliance and relative Immergas accessories must have suitable features (technical and structural), such as to allow for (always in safe, efficient and comfortable conditions):

- installation (according to the provisions of technical legislation and technical regulations);
- maintenance operations (including scheduled, periodic, routine and special maintenance);
- removal (to outdoors in the place for loading and transporting the appliances and components) as well as the eventual replacement of those with appliances and/or equivalent components.



The wall surface must be smooth, without any protrusions or recesses enabling access to the rear part. They are not designed to be installed on plinths or floors (Fig. 1).



By varying the type of installation the classification of the boiler also varies, precisely:

- **Type B₂₃ or B₅₃** boiler if installed using the relevant terminal for air intake directly from the room in which the boiler has been installed.
- **Type C boiler** if installed using concentric pipes or other types of pipes envisioned for the sealed chamber boiler for intake of air and expulsion of flue gas.



Only professionally enabled companies are authorised to install Immergas gas appliances.



The equipment classification is shown in the illustrations of the various installation solutions on the following pages.



Installation must be carried out according to regulation standards, current legislation and in compliance with local technical regulations and the required technical procedures.

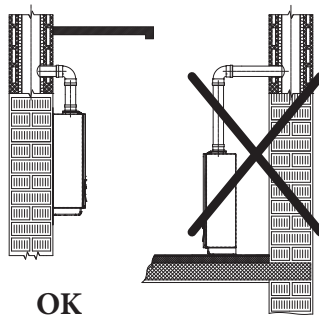

OK

1



Check the environmental operating conditions of all parts relevant to installation, referring to the values shown in the technical data table in this booklet.



Installation of the boiler when powered by LPG or propane air supply must comply with the rules regarding gases with a greater density than air (remember, as an example, that it is prohibited to install plants powered with the above-mentioned gas in rooms where the floor is at a lower quota than the country level).



If installing a kit or servicing the appliance, always empty the system's domestic hot water circuit first so as not to compromise the appliance's electrical safety (Parag. 2.10, 2.11).

Always disconnect the appliance from voltage and, depending on the type of operation, decrease the pressure and/or bring it to zero in the gas and DHW circuits.



If the boiler is connected to a low temperature direct area, it is necessary to check the necessary flow rate and, if necessary, add a booster pump.



It is just as important that the intake grids and exhaust terminals are not obstructed.



Check that no flue gas recirculation is found in the air sample points. Allow the appliance to reach the maximum heat output; the CO₂ value measured in the air must be less than 10% of that measured on the flue gas.



The minimum distance for exhaust pipes from flammable materials must be at least 25 cm.



Keep all flammable objects away from the appliance (paper, rags, plastic, polystyrene, etc.).



Do not place household appliances underneath the boiler as they could be damaged if the safety valve intervenes, if the drain trap is blocked, or if there are leaks from the hydraulic connections; otherwise, the manufacturer cannot be held responsible for any damage caused to the household appliances.



For the aforementioned reasons, we recommend not placing furnishings, furniture, etc. under the boiler.



In the event of malfunctions, faults or incorrect operation, turn the appliance off and contact an authorised company (e.g. the Authorised Technical Assistance Centre, which has specifically trained staff and original spare parts). Do not attempt to modify or repair the appliance alone.



Any modification to the appliance that is not explicitly indicated in this section of the booklet is forbidden.



It is forbidden to install appliances removed from other systems.

The manufacturer declines all liability in the event of damage caused by appliances removed from other systems or for any non-conformities with such equipment.



Before installing the appliance, ensure that it is delivered in perfect condition; if in doubt, contact the supplier immediately. Packing materials (staples, nails, plastic bags, polystyrene foam, etc.) constitute a hazard and must be kept out of the reach of children.

If the appliance is installed inside or between cabinets, ensure sufficient space for routine servicing; for minimum installation distances, see Fig. 3.

Installation standards



This type of installation is possible when permitted by the laws in force in the appliance's country of destination.



This boiler can be installed outdoors in a partially protected area. A partially protected area is one in which the boiler is not exposed to the direct action of the weather (rain, snow, hail, etc.).



Installation of gas appliances, flue exhaust pipes and combustion air intake pipes is forbidden in places with a fire risk (for example: garages, closed parking stalls), and in potentially dangerous places.



Do not install on the vertical projection of hobs.



Do not install in places/rooms that constitute public areas of apartment buildings, internal stairways or other escape routes (e.g. floor landings, entrance halls, etc.).



Installation is also forbidden in places/rooms that constitute public areas of apartment buildings such as cellars, entrance halls, attics, lofts, etc., unless otherwise provided for by local regulations in force.



These boilers, unless properly isolated, are not suitable for installation on walls made of combustible material.



The installation of the boiler on the wall must guarantee a stable and effective support to the generator itself.

The plugs (standard supply) are only to be used to fix the boiler to the wall; they only ensure adequate support if inserted correctly (according to technical standards) in walls made of solid or semi-hollow brick or block. In the case of walls made from hollow brick or block, partitions with limited static properties, or in any case walls other than those indicated, a static test must be carried out to ensure adequate support.



These boilers are used to heat water to below boiling temperature in atmospheric pressure.



They must be connected to a central heating system and domestic hot water circuit suited to their performance and capacity.

“Anti-legionella” thermal treatment of the accumulation storage tank.



The anti-Legionella function is programmed directly on the control panel.

During this phase, the temperature of the water inside the tank exceeds 60°C with the subsequent risk of burns. Keep this domestic hot water treatment under control (and inform the users) to prevent unforeseeable damage to people, animals, things. If required install a thermostatic valve on the domestic hot water outlet to prevent scalding.

Risk of damage due to corrosion caused by unsuitable combustion air and environment.

Spray, solvents, chlorine-based detergents, paints, glue, ammonium compounds, powders and similar cause product and flue duct corrosion.



Check that combustion air power supply is free from chlorine, sulphur, powders, etc.



Make sure that no chemical substances are stored in the place of installation.



If you want to install the product in beauty salons, paint workshops, carpenter's shop, cleaning companies or similar, choose a separate installation area that ensures combustion air supply that is free from chemical substances.



Make sure the combustion air is not fed from chimneys that were used with gas boilers or other heating devices. In fact, these may cause an accumulation of soot in the chimney.

Risk of material damage after using sprays and liquids to search for leaks

Leak sprays and liquids clog the reference hole P.Ref. (Fig. 55) of the gas valve, damaging it irreparably. During installation and maintenance, do not use spray or liquids in the upper area of the gas valve (side referring to the electric connections).

Filling the condensate drain trap

On first lighting of the boiler, flue gas may come out the condensate drain; after a few minutes' operation check that this no longer occurs. If this is the case, the drain trap is correctly filled with condensate up to a height that does not allow the flue gas to pass.



Type B open chamber boilers must not be installed in places where commercial, artisan or industrial activities take place, which use products that may develop volatile vapours or substances (e.g. acid vapours, glues, paints, solvents, combustibles, etc.), as well as dusts (e.g. dust deriving from the working of wood, coal fines, cement, etc.), which may be damaging for the components of the appliance and jeopardise functioning.



Unless otherwise provided for by local regulations in force, in configurations B₂₃ and B₅₃, the boilers must not be installed in bedrooms, bathrooms or bedsits. Moreover, they must not be installed in places where solid fuel heat generators are present and in adjoining rooms.



The installation rooms must be permanently ventilated, in compliance with the local regulations in force (at least 6 cm² for every kW of installed heat input, except in the event of any increases needed for electro-mechanical vacuum cleaners or other devices that could put the installation room under vacuum).



Install the appliances in B₂₃ and B₅₃ configuration in non-residential premises and which are permanently ventilated.



Failure to comply with the above implies personal responsibility and invalidates the warranty.

INSTALLER

USER

MAINTENANCE TECHNICIAN

TECHNICAL DATA

1.2 MAIN DIMENSIONS

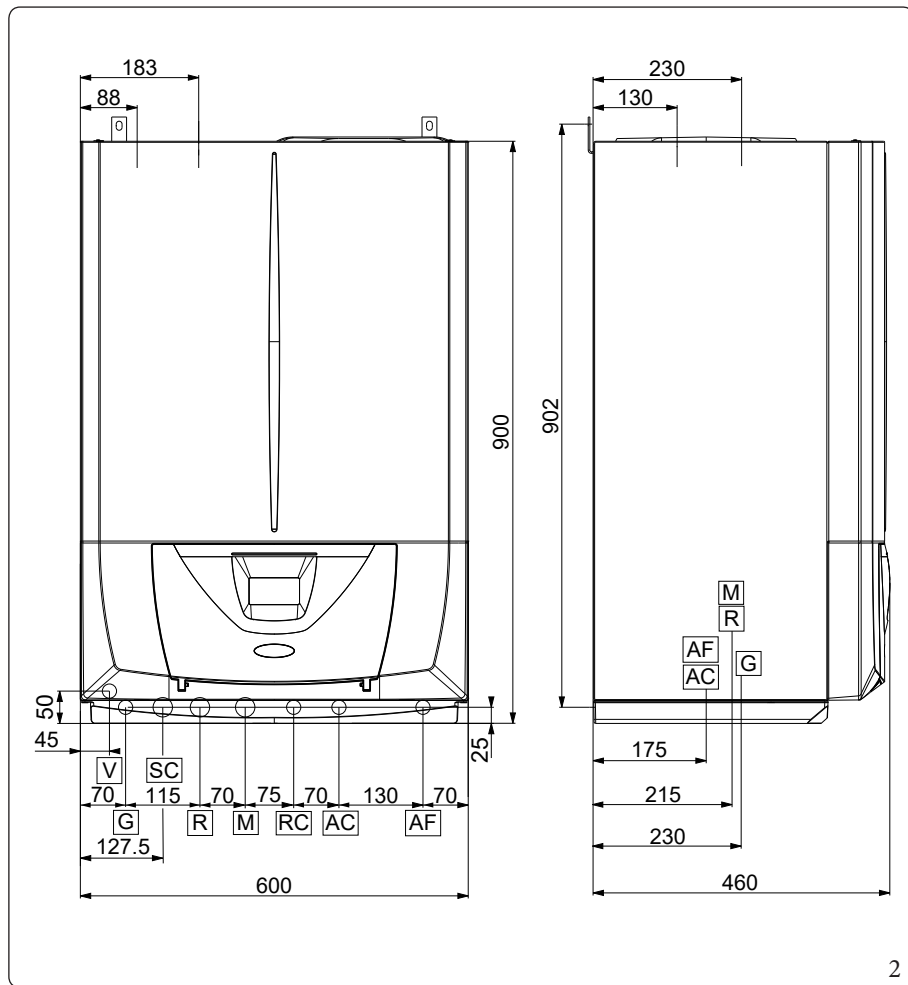

Key (Fig. 2):

- V - Electrical connection
- G - Gas supply
- SC - Condensate drain (minimum internal diameter \varnothing 13 mm)
- R - System return
- M - System flow
- RC - Domestic hot water pump (optional)
- AC - Domestic hot water outlet
- AF - Domestic hot water inlet

Height (mm)	Width (mm)		Depth (mm)	
900	600		450	
TEMPLATE CONNECTIONS				
GAS	D.H.W.		SYSTEM	
G	AC	AF	R	M
1/2"	1/2"	1/2"	3/4"	3/4"

1.3 MINIMUM INSTALLATION DISTANCES

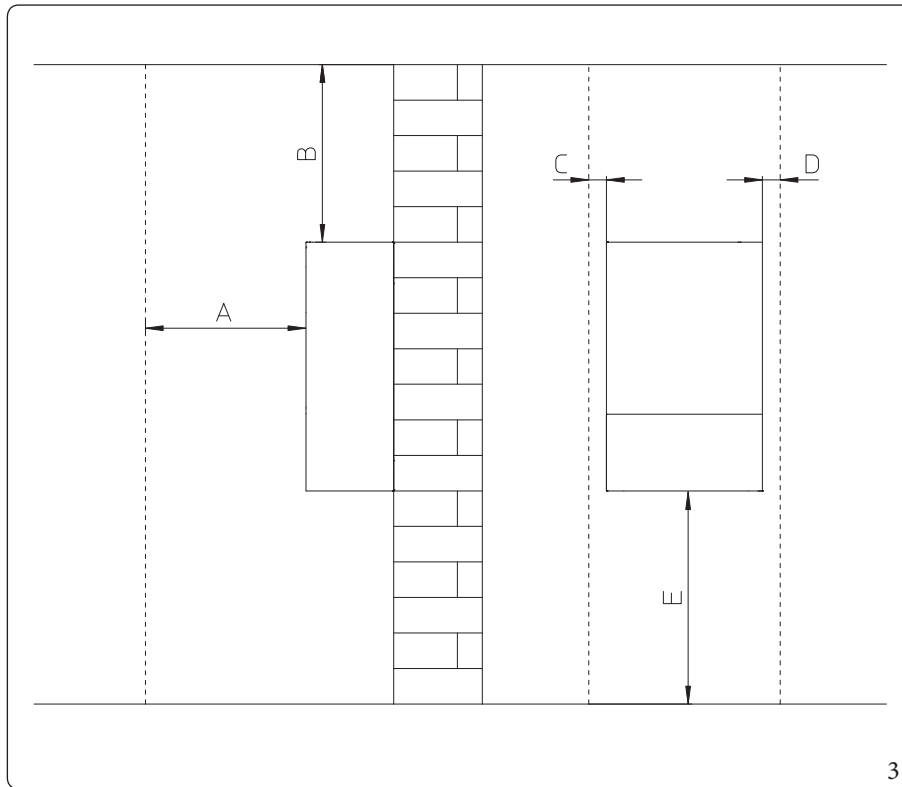

Key (Fig. 3):

- A - 450 mm
- B - 350 mm
- C - 30 mm
- D - 30 mm
- E - 600 mm

1.4 ANTIFREEZE PROTECTION

Minimum temperature 0°C

The boiler is equipped as standard with an antifreeze function that starts the pump and burner when the water temperature inside the boiler drops below 4°C.

i In these conditions the boiler is protected against freezing to an ambient temperature of 0°C.

! If the boiler is installed in a place where the temperature drops below 0°C, the appliance can freeze.

To prevent the risk of freezing follow the instructions below:

! The excessive use of glycol could jeopardise the proper functioning of the appliance.

- Protect the central heating circuit from freezing by inserting a good-quality antifreeze liquid into this circuit, which is especially suited for central heating systems and which is manufacturer guaranteed not to cause damage to the heat exchanger or other components of the boiler. The antifreeze liquid must not be harmful to one's health. The instructions of the manufacturer of this liquid must be followed scrupulously regarding the percentage necessary with respect to the minimum temperature at which the system must be kept.
- The materials used for the central heating circuit of Immergas boilers resist ethylene and propylene glycol based antifreeze liquids (if the mixtures are prepared perfectly).
- An aqueous solution must be made with potential pollution class of water 2 (EN 1717:2002 or local standards in force).

! For life and possible disposal, follow the supplier's instructions.

INSTALLER

USER

MAINTENANCE TECHNICIAN

TECHNICAL DATA

Minimum temperature -15°C



In these conditions the boiler is protected against freezing to temperature of -15°C.

- Protect the domestic hot water circuit against freezing by using an accessory that is supplied on request (antifreeze kit) comprising two electric heating elements, the relevant wiring and a control thermostat (carefully read the installation instructions contained in the accessory kit pack).

Boiler antifreeze protection is thus ensured only if:

- the boiler is correctly connected to gas and electricity power supply circuits;
- the boiler is constantly powered;
- the boiler is not in "off" mode;
- the boiler is not in anomaly conditions (Par. 2.7);
- the essential components of the boiler are not faulty.

The warranty does not cover damage due to interruption of the electrical power supply and failure to comply with that stated on the previous page.



If the boiler is installed in places where the temperature falls below 0°C the domestic hot water and central heating attachment pipes and the condensate drain pipe must be insulated.



The freezing protection systems described in this chapter are installed only for the protection of the boiler. The presence of these functions and devices does not exclude the possibility of parts of the system or domestic hot water circuit outside the boiler from freezing.

1.5 BOILER CONNECTION GROUP

The connection unit consisting of all the necessary parts to perform the hydraulic and gas system connections of the appliance comes as standard with the boiler, perform the connections in accordance with the type of installation to be made and respecting the arrangement shown in the figure.

(Fig. 4):

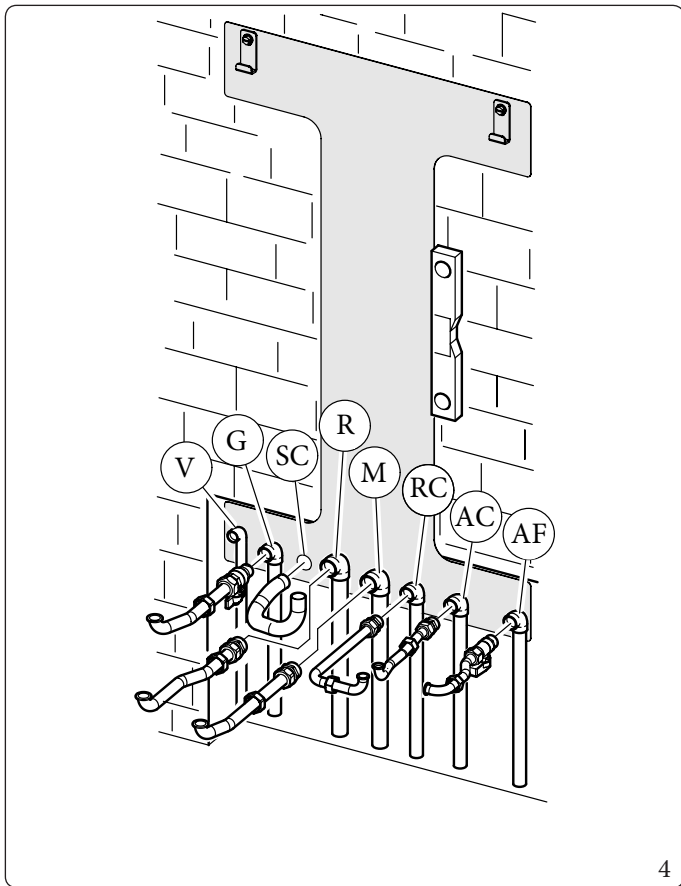

4

The unit includes:

- N°2 - 3/4" telescopic fittings (R-M)
- N°1 - 1/2" telescopic fitting (AC)
- N°1 - 1/2" gas cock (G)
- N°1 - 1/2" ball valve (AF)
- N°3 - Ø18 copper bends
- N°2 - Ø14 copper bends
- N°2 - adjustable expansion bolts
- N°2 - boiler support hooks
- N°1 - filling knob

Key (Fig. 4):

- V - Electrical connection 230V-50Hz
- G - 1/2" gas supply
- SC - Condensate drain
- R - 3/4" system return
- M - 3/4" System flow
- RC - 1/2" domestic hot water recirculation (optional)
- AC - 1/2" domestic hot water outlet
- AF - 1/2" domestic hot water inlet

1.6 GAS CONNECTION

Our boilers are designed to operate with methane gas (G20) LPG and propane air (50% air - 50% propane). Power supply pipes must be the same as or larger than the boiler fitting.



Before connecting the gas line, carefully clean inside all the fuel feed system pipes to remove any residue that could impair boiler efficiency.

Also make sure the gas corresponds to that for which the boiler is prepared (see boiler data nameplate).

If different, the boiler must be converted for operation with the other type of gas (see converting appliance for other gas types).



It is also important to check the dynamic pressure of the mains (methane or LPG) used to supply the boiler, which must comply with EN 437 and its attachment, as insufficient levels may reduce generator output and cause discomfort to the user.

Static/dynamic network pressures higher than those required for regular operation may cause serious damage to the appliance control elements; in this case shut the gas line off.

Do not operate the device.

Have the device checked by experienced personnel.



According to the local regulation in force, make sure that a gas cock is installed upstream of each connection between the appliance and the gas system. This cock, if supplied by the appliance's manufacturer, can be directly connected to the appliance (i.e. downstream from the pipes connecting the system to the appliance), according to the manufacturer's instructions.

The Immergas connection unit, supplied as an optional kit, also includes the gas cock, whose installation instructions are provided in the kit.

In any case, make sure the gas cock is connected properly.

The gas supply pipe must be suitably dimensioned according to current regulations in order to guarantee correct gas flow rate to the burner even in conditions of maximum generator output and to guarantee appliance efficiency (technical specifications).

The coupling system must conform to standards in force (EN 1775).



The appliance is designed to operate with fuel gas free from impurities; otherwise it is advisable to fit special filters upstream of the appliance to restore the purity of the fuel.

Storage tanks (in case of supply from LPG depot).

- New LPG storage tanks may contain residual inert gases (nitrogen) that degrade the mixture delivered to the appliance causing functioning anomalies.
- Due to the composition of the LPG mixture, layering of the mixture components may occur during the period of storage in the tanks. This can cause a variation in the calorific value of the mixture delivered to the appliance, with subsequent change in its performance.

1.7 HYDRAULIC CONNECTION



In order not to void the condensation module warranty before making the boiler connections, carefully clean the heating system (pipes, radiators, etc.) with special pickling or descaling products to remove any deposits that could compromise correct boiler operation.

3 bar safety valve

The drain of the safety valve must always be properly conveyed to a draining funnel; consequently, in case of valve operation, the leaked fluid will end up in the sewer system.

Condensate drain

To drain the condensate produced by the appliance, it is necessary to connect to the drainage system by means of acid condensate resistant pipes, with an internal Ø of at least 13 mm.

The system connecting the appliance to the drainage system must be carried out in such a way as to prevent occlusion and freezing of the liquid contained in it.

Before appliance ignition, ensure that the condensate can be correctly removed. After first ignition, check that the drain trap is filled with condensate.

Also, comply with national and local regulations on discharging waste waters.

In the event condensate is not discharged into the wastewater drainage system, a condensate neutraliser must be installed to ensure compliance with the parameters established by the legislation in force.

A treatment of the heating and water system water is required, in compliance with the technical standards in force, in order to protect the system and the appliance from deposits (e.g. scale), slurry or other hazardous deposits.

In order not to void the heat exchanger warranty, you are required to comply with what has been prescribed (Par. 1.27).

Water connections must be made in a rational way using the couplings on the boiler template.



The manufacturer declines all liability in the event of damage caused by the installation of an automatic filling system.

In order to meet the system requirements established by EN 1717 in terms of pollution of drinking water, we recommend installing the IMMERGAS anti-backflow kit to be used upstream of the cold water inlet connection of the boiler. We also recommend using category 2 heat transfer fluid (ex: water+glycol) in the boiler's primary circuit (C.H. circuit), as defined in standard EN 1717.



To preserve the duration of appliance efficiency features, in the presence of water whose features can lead to the deposit of lime scale, installation of the "polyphosphate dispenser" kit is recommended.

1.8 ELECTRICAL CONNECTION

The appliance has an IPX5D protection degree; electrical safety of the appliance is achieved only when it is connected properly to an efficient earthing system, as specified by current safety standards.



The manufacturer declines any responsibility for damage or physical injury caused by failure to connect the boiler to an efficient earthing system or failure to comply with the IEC reference standards.

Open the control panel connections compartment (Fig. 5).



The power supply cable must be connected to a 230V \pm 10% / 50Hz mains supply respecting L-N polarity and earth connection; this network must also have a multi-pole circuit breaker with class III overvoltage category in compliance with installation regulations.

To carry out electrical connections, all you have to do is open the connections compartment as follows.

1. Remove the front panel (Fig. 64 - 65)
2. Loosen the screws (a).
3. Remove the cover (b) from the control panel (c).

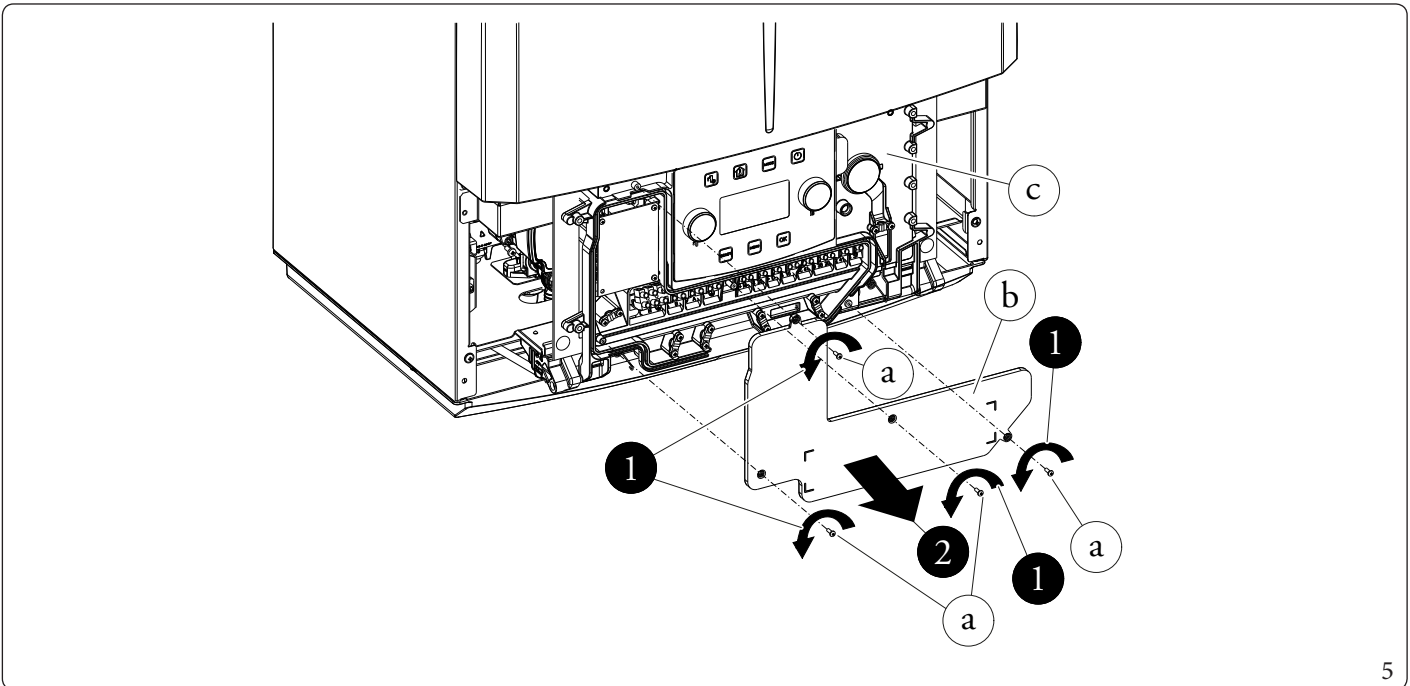

5

At this point, you can access the terminal board.

Also ensure that the electrical installation corresponds to maximum absorbed power specifications as shown on the boiler data nameplate.

The boilers are supplied complete with a "Y" type H 05 VVF 3 x 0.75 mm² power supply cable, without plug.



To protect from possible dispersions of DC voltage, it is necessary to provide a type A differential safety device.



If the power cable is damaged, contact a qualified company (e.g. the Authorised Technical Assistance Centre) for its replacement to avoid a hazard.

The power cable must be laid as shown (Fig. 6);

If the network fuse on the P.C.B. needs replacing, this must also be done by qualified personnel: use a 5x20 250V 3.15 A fast fuse.

Key (Fig. 6):

A - Power supply cable

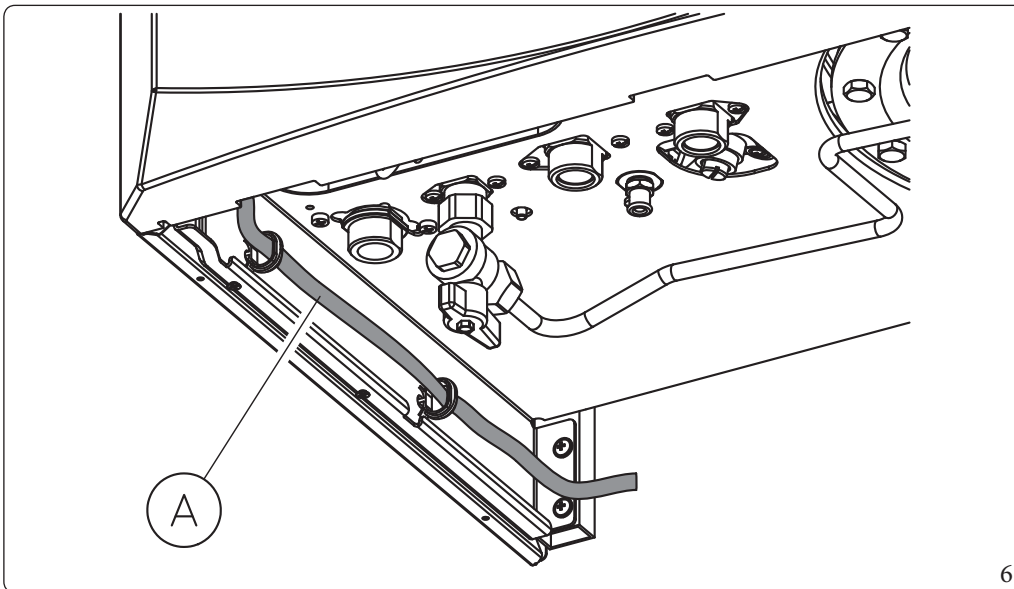

Installation with system operating at direct low temperature

The boiler can directly feed a low temperature system by acting on the "Menu - Service - Domestic Hot Water" parameter (Par. 2.6) and setting the flow temperature adjustment range "DHW min set" and "DHW max set"; in this situation, it is advisable to insert a safety device consisting of a thermostat with a limit temperature of 55°C in series with the boiler power supply.

Execute connection to terminal boards 14 and 15, eliminating jumper X70 (Fig. 52).

The thermostat must be positioned on the system flow pipe at a distance of at least 2 metres from the boiler.

1.9 REMOTE CONTROLS AND ROOM CHRONO-THERMOSTATS (OPTIONAL)

The boiler is prepared for the application of room chrono-thermostats or remote controls, which are available as optional kits.

All Immergas chrono-thermostats are connected with 2 wires only.

Carefully read the user and assembly instructions contained in the accessory kit.



Disconnect power to the unit before making any electrical connections.

"Comando Amico Remoto" (Remote Control Device) ^{v2} (CAR^{v2}) with climate chrono-thermostat function.

In addition to the functions described in the previous point, the CAR^{v2} panel enables the user to control all the important information regarding operation of the appliance and the heating system with the opportunity to easily intervene on the previously set parameters, without having to go to where the appliance is installed.

The panel is provided with self-diagnosis to display any boiler functioning anomalies.

The climate chrono-thermostat incorporated into the remote panel enables the system flow temperature to be adjusted to the actual needs of the room being heated, in order to obtain the desired room temperature with extreme precision and therefore with evident saving in running costs.

The CAR^{v2} is fed directly by the boiler by means of the same 2 wires used for the transmission of data between the boiler and device.



In case the system is divided into more zones, the CAR^{v2} can only manage zone 1.

In multi-zone systems it is possible to manage a "modulating" radiator flow temperature for each zone in case of wireless room probes (optional) presence.

"Comando Amico Remoto" (Remote Control Device) ^{v2} or On/Off chrono-thermostat electrical connection (Optional).



The operations described below must be performed after having removed the voltage from the appliance.



If the Comando Amico Remoto remote control^{V2} or any other On/Off chrono-thermostat is used arrange two separate lines in compliance with current regulations regarding electrical systems.

No appliance pipes must ever be used to earth the electric system or telephone lines.

Ensure elimination of this risk before making the boiler electrical connections.

Any room thermostat or ON-OFF must be connected to terminals 40 and 41 eliminating jumper X40.

Any CAR^{V2} must be connected to terminals 44 and 41 complying with the polarity **without eliminating jumper X40**.

Make sure that the On/Off thermostat contact is of the “clean” type, i.e. independent of the mains voltage, otherwise the P.C.B. would be damaged.

Dialogue to remote devices (Optional)

On this path it is possible to select different remote control modes (connected to terminals 44-41):

Assistance/Inputs/Remote control

- **Remote control = IMG BUS:** it is the default condition for correct dialogue with the CAR^{V2} devices. In this condition, the selection of the operating mode, DHW (Domestic hot water) set, central heating / C.H. set and the central heating / C.H. request (for zone 1 in case of system divided into several zones) are fully managed by CAR^{V2}. The anti-legionella function can be activated on the boiler in the usual way.
- **Remote control = 1:** it is possible to manage the DHW Mode entirely and solely via the boiler (set, boost, anti-legionella management). This type of dialogue is recommended for commercial remote devices, other than CAR^{V2}. The remote control will remain in control of the “Operating mode”, “Set Central heating / C.H.” and “Central heating / C.H. demand”.

1.10 EXTERNAL TEMPERATURE PROBE (OPTIONAL)

The boiler is designed for the application of the external temperature probe (Fig. 7) which is available as an optional kit.

Refer to the relative instruction sheet for positioning of the external probe.

The probe can be connected directly to the boiler electrical system and allows the max. system flow temperature to be automatically decreased when the external temperature increases, in order to adjust the heat supplied to the system according to the change in external temperature.

The external probe always operates when connected, regardless of the presence or type of room chrono-thermostat used and can work in combination with Immergas chrono-thermostats and wireless room probes.

If wireless room probes are used, it is possible to activate or deactivate the action of the external probe for each individual zone in use, by acting on the parameter in the zone menu.

The electric connection of the external probe must be made on terminals 38 and 39 on the terminal board in the boiler control panel (Fig. 52).

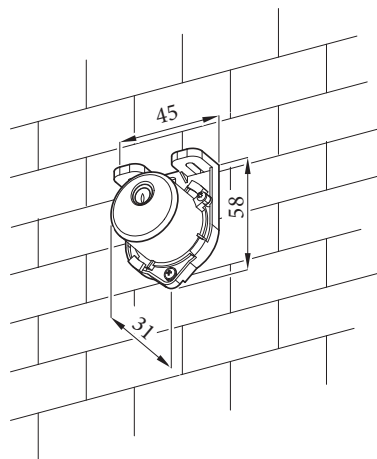

7

1.11 FLOW TEMPERATURE PROBE (OPTIONAL)

The sensor must be positioned on the central heating system flow pipe common to all requesting zones, downstream of any by-pass on the system return, in order to measure the actual temperature “detected” by each requesting zone.

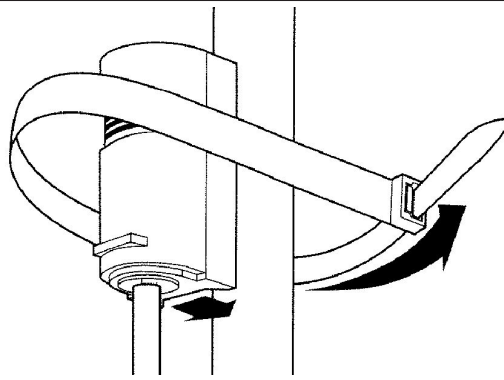

The probe must be connected to the boiler terminal board terminals 38 and 20 using electrical cables with section between 0.3 and 1.5 sq.mm.



If the flow temperature probe is used, arrange two separate lines in compliance with current regulations regarding electrical systems.

It is necessary to activate the temperature control function on the flow probe on the boiler parameter by accessing the Menu with "Service" recognition at the path:

Service\Inputs\Configurable input

And setting Configurable inlet = Flow temp

By reading the flow probe, it will be possible to permit the boiler to increase the central heating / C.H. system flow temperature (with respect to the set obtained from the normal management of the central heating / C.H. requests).

The maximum increase can be set on the boiler parameter menu.

To vary the maximum increase value, access the Menu with "Service" credentials to path:

Service\Central Heating>Edit max common flow pr

This parameter setting can vary from 5 to 15°C (default 5°C).



On the display, the central digits will always show the boiler outlet temperature. With flow probe in correction, it will be higher than the required central heating / C.H. set.

1.12 TEMPERATURE CONTROL SETTING

By setting the parameters in the "Zones/Definition/Regulation" menus (with Service access), it is possible to automatically adjust the flow temperature of each zone according to the outdoor temperature.

This can be done by enabling the external probe modulation in the menu "Zones/Definition/Regulation" (Default = Yes).

The curves (Fig. 9, 10) show the default settings in the various operating modes available both with external probe and without.

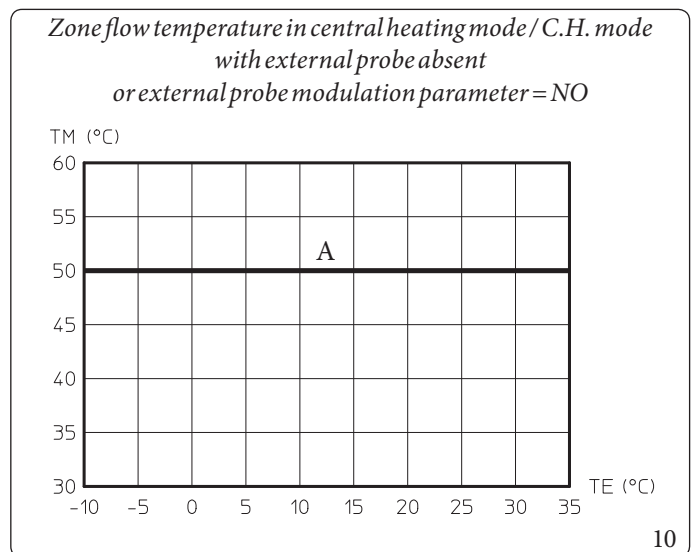
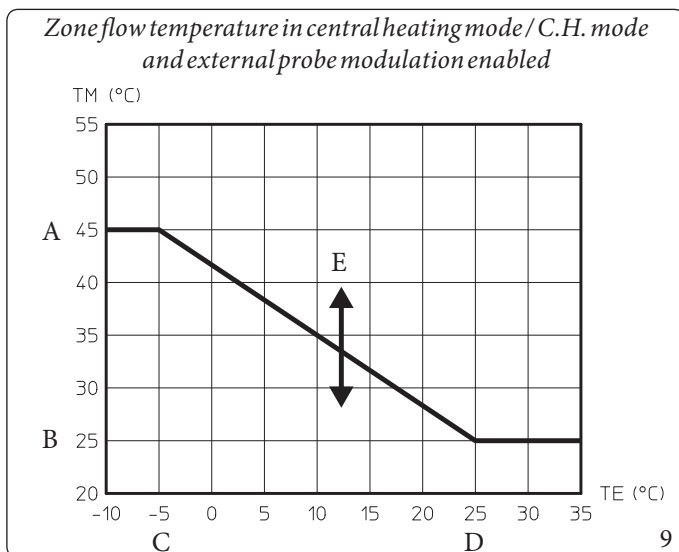

Key (Fig. 9, 10)

- A - Maximum flow set
- B - Minimum flow set*
- C - Minimum external temperature*
- D - Maximum external temperature*
- E - Climatic curve offset

*Functions reserved for Service

1.13 IMMERGAS FLUE SYSTEMS

Immergas supplies various solutions separately from the boilers regarding the installation of air intake terminals and flue exhaust, which are fundamental for boiler operation.



The boiler must be installed with an original Immergas “Green Range” inspectionable air intake system and visible flue gas extraction system made of plastic, with the exception of the C₆ configuration, as required by the regulations in force and by the product’s approval. This flue system can be identified by the specific identification mark bearing the following indication: “only for condensation boilers”.

For non-original flue system, refer to the technical data of the appliance.



The plastic pipes cannot be installed outdoors, for tracts longer than 40 cm, without suitable protection from UV rays and other atmospheric agents.

Resistance factors and equivalent lengths

Each flue component has a Resistance Factor based on experimental tests and specified in the table below.

The Resistance Factor for individual components is independent from the type of boiler on which it is installed and has a dimensionless size.

It is however, conditioned by the temperature of the fluids that pass through the pipe and therefore, varies according to applications for air intake or flue exhaust.

Each single component has a resistance corresponding to a certain length in metres of pipe of the same diameter; the so-called equivalent length, can be obtained from the ratio between the relative Resistance Factors.

All boilers have an experimentally obtainable maximum Resistance Factor (R) equal to 100.

The maximum Resistance Factor allowed corresponds to the resistance encountered with the maximum allowed pipe length for each type of Terminal Kit.

This information allows calculations to be made to verify the possibility of setting up various flue configurations.



To dimension the flue ducting using commercial components, refer to the table of combustion parameters (Par. 4.2).

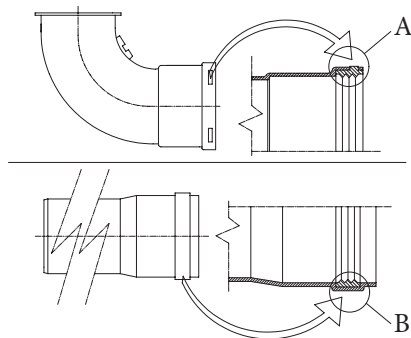

11

Positioning the gaskets (black) for “green range” flue systems.

Position the gasket correctly (for bends and extensions) (Fig. 11):

- gasket (A) with notches, to use for bends;
- gasket (B) without notches, to use for extensions.

If necessary, to ease the push-fitting, spread the elements with commonly-used talc.

Extension pipes and concentric elbows push-fittings.

To install push-fitting extensions with other elements of the flue, proceed as follows:

- Install the concentric pipe or elbow with the male side (smooth) on the female side (with lip seal) to the end stop on the previously installed element in order to ensure sealing efficiency of the coupling.



If the exhaust terminal and/or extension concentric pipe needs shortening, consider that the internal duct must always protrude by 5 mm with respect to the external duct.







For safety purposes, do not obstruct the boiler intake/exhaust terminal, even temporarily. The various parts of the flue system must be checked to ensure that they have been laid in such a way as to prevent the coupled parts from detaching, in particular, the flue exhaust duct in the Ø80 separator kit configuration. If the condition described above is not adequately guaranteed, it will be necessary to use the appropriate retaining clamp kit.







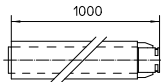
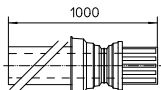





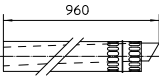

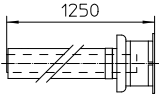
When installing horizontal pipes, a minimum inclination of 1.5% towards the boiler must be maintained, and a section clip with pin must be installed every 3 metres.

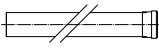
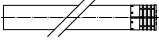
All boilers have an experimentally obtainable maximum Resistance Factor (R) equal to 100.

1.14 TABLES OF RESISTANCE FACTORS AND EQUIVALENT LENGTHS OF “GREEN RANGE” FLUE SYSTEM COMPONENTS

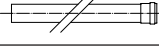
TYPE OF DUCT		Resistance Factor (R)	Equivalent length in m of concentric pipe Ø 80/125
Concentric pipe 80/125 Ø m 1		2,1	1
90° concentric bend 80/125 Ø		3,0	1,4
Concentric bend 45° Ø 80/125		2,1	1
Terminal complete with concentric horizontal intake-exhaust Ø 80/125		2,8	1,3
Terminal complete with concentric vertical intake-exhaust Ø 80/125		3,6	1,7
90° concentric bend Ø 80/125 with inspection		3,4	1,6
Stub pipe with inspection Ø 80/125		3,4	1,6

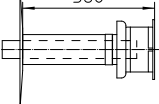
TYPE OF DUCT		Resistance factor (R)	Equivalent length in m of concentric pipe Ø 60/100	Equivalent length in m of pipe Ø 80	Equivalent length in m of pipe Ø 60	Equivalent length in m of concentric pipe Ø 80/125
Concentric pipe Ø 60/100 m 1		Intake m 6.4	m 1	Intake m 7.3	Exhaust m 1.9	m 3,0
		Exhaust m 6.4		Exhaust m 5,3		
90° concentric bend Ø 60/100		Intake m 8.2	m 1,3	Intake m 9.4	Exhaust m 2.5	m 3,9
		Exhaust m 8.2		Exhaust m 6.8		
45° concentric bend Ø 60/100		Intake m 6.4	m 1	Intake m 7.3	Exhaust m 1.9	m 3,0
		Exhaust m 6.4		Exhaust m 5,3		
Terminal complete with concentric horizontal intake-exhaust Ø 60/100		Intake m 15	m 2,3	Intake m 17.2	Exhaust m 4.5	m 7,1
		Exhaust m 15		Exhaust m 12.5		
Concentric horizontal intake-exhaust terminal Ø 60/100		Intake m 10	m 1,5	Intake m 11.5	Exhaust m 3.0	m 4,7
		Exhaust m 10		Exhaust m 8.3		
Terminal complete with concentric vertical intake-exhaust Ø 60/100		Intake m 16.3	m 2,5	Intake m 18.7	Exhaust m 4.9	m 7,7
		Exhaust m 16.3		Exhaust m 13.6		
Concentric vertical intake-exhaust terminal Ø 60/100		Intake m 9	m 1,4	Intake m 10.3	Exhaust m 2.7	m 4,3
		Exhaust m 9		Exhaust m 7.5		
Pipe Ø 80 m 1		Intake m 0.87	m 0,1	Intake m 1.0	Exhaust m 0.4	m 0,4
		Exhaust m 1.2	m 0,2	Exhaust m 1.0		m 0,5
Complete intake terminal Ø 80 m 1		Intake m 3	m 0,5	Intake m 3.4	Exhaust m 0.9	m 1,4
Intake terminal Ø 80 Exhaust terminal Ø 80		Intake m 2.2	m 0,35	Intake m 2.5	Exhaust m 0.6	m 1
		Exhaust m 1.9	m 0,3	Exhaust m 1.6		m 0,9
90° bend Ø 80		Intake m 1.9	m 0,3	Intake m 2.2	Exhaust m 0.8	m 0,9
		Exhaust m 2.6	m 0,4	Exhaust m 2.1		m 1,2
45° bend Ø 80		Intake m 1.2	m 0,2	Intake m 1.4	Exhaust m 0.5	m 0,5
		Exhaust m 1.6	m 0,25	Exhaust m 1.3		m 0,7
Pipe Ø 60 m 1 for ducting		Exhaust m 3.3	m 0,5	Intake m 3.8	Exhaust m 1.0	m 1,5
				Exhaust m 2.7		
90° bend Ø 60 for ducting		Exhaust m 3.5	m 0,55	Intake m 4.0	Exhaust m 1.1	m 1,6
				Exhaust m 2.9		
Reduction Ø 80/60		Intake m 2.6	m 0,4	Intake m 3	Exhaust m 0.8	m 1,2
		Exhaust m 2.6		Exhaust m 2.1		
Terminal complete with vertical exhaust Ø 60 for piping		Exhaust m 12.2	m 1,9	Intake m 14	Exhaust m 3.7	m 5,8
				Exhaust m 10.1		

INSTALLER

USER

MAINTENANCE TECHNICIAN

TECHNICAL DATA

1.15 OUTDOOR INSTALLATION IN PARTIALLY PROTECTED AREA



A partially protected area is one in which the appliance is not exposed to the direct action of the weather (rain, snow, hail, etc.).



If the appliance is installed in a place where the ambient temperature drops below 0°C, use the optional antifreeze kit, checking the ambient operating temperature range shown in the technical data table in this instruction booklet.

INSTALLER

Configuration type B, open chamber and fan assisted (B₂₃ or B₅₃).

Using the special coverage kit one can achieve direct air intake and flue gas exhaust in a single chimney or directly outside. In this configuration it is possible to install the boiler in a partially protected place. In this configuration the boiler is classified as type B.

With this configuration:

- air intake takes place directly from the environment in which the appliance is installed (external);
- the flue gas exhaust must be connected to its own single chimney (B₂₃) or ducted directly outside via a vertical terminal for direct exhaust (B₅₃) or via an Immergas ducting system (B₅₃).

The technical regulations in force must be respected.

Cover kit assembly (Fig. 13).

Remove the cap and gasket from the intake hole.

Install the Ø 80 outlet flange on the hole in correspondence with the flange with sample points of the boiler, taking care to insert the gasket supplied with the kit and tighten by means of the screws provided.

Install the upper cover, fixing it using the 4 screws present in the kit, positioning the relevant gaskets.

Engage the 90° Ø 80 bend with the male end (smooth) in the female end (with lip seal) of the Ø 80 flange unit to the end stop. Introduce the gasket, making it run along the bend. Fix it using the metal sheet plate and tighten by means of the clips present in the kit, making sure to block the 4 gasket flaps.

Fit the male end (smooth) of the exhaust pipe into the female end of the 90° bend or Ø 80 extension, making sure that the relevant wall sealing plate is already fitted; this will ensure hold and joining of the elements making up the kit.

Max. length of exhaust duct.

The flue pipe (both vertical or horizontal) can be extended to a max. length of 30 linear metres.

Coupling of extension pipes.

To install push-fitting extensions with other elements of the flue, proceed as follows: Couple the pipe or elbow with the male side (smooth) in the female side (with lip seal) to the end stop on the previously installed element. This will ensure sealing efficiency of the coupling.

Configuration without cover kit in a partially protected location (type C boiler).

By leaving the intake plug fitted it is possible to install the appliance externally without the cover kit.

Installation takes place using the Ø 60/100 and Ø 80/125 concentric intake/ exhaust kits. Refer to the paragraph on indoor installation.

In this configuration the Top cover kit guarantees an additional protection for the boiler. It is recommended with Ø 60/100 concentric and it is mandatory with Ø 80 exhaust.

The Ø 80/80 separating device cannot be used in this configuration (coupled with the cover kit).

USER

MAINTENANCE TECHNICIAN

TECHNICAL DATA

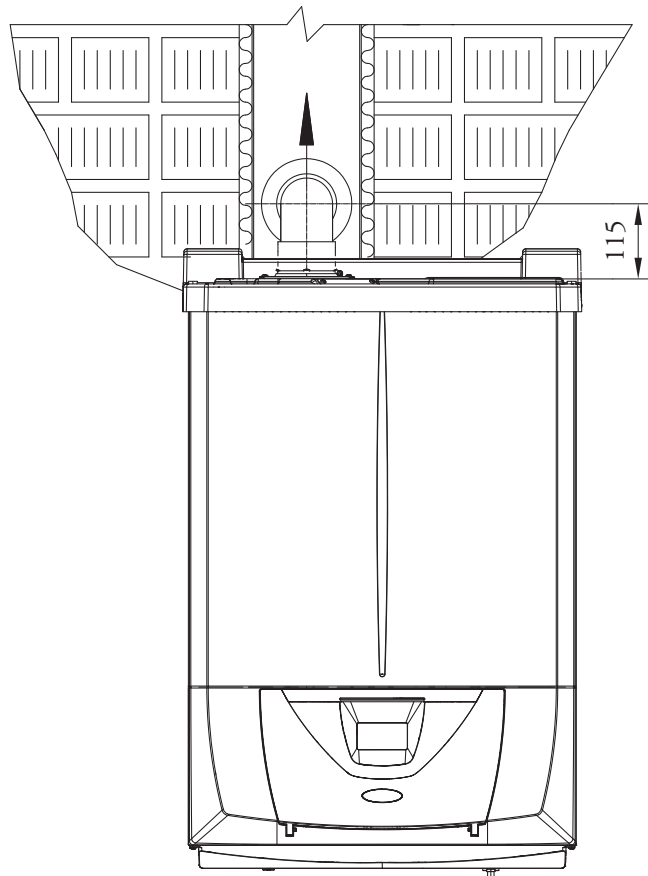

12

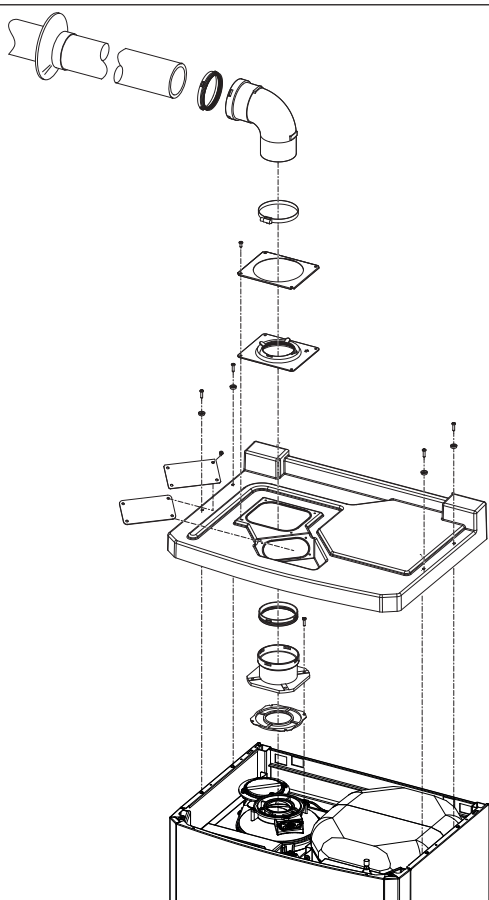

13

The cover kit includes (Fig. 13):

- N°1 Thermoformed cover
- N°1 Gasket clamping plate
- N°1 Gasket
- N°1 Gasket tightening clip
- N°1 Flange plate with sample points

The terminal kit includes (Fig. 13):

- N°1 Gasket
- N°1 Exhaust flange Ø80
- N°1 Ø80 90° bend
- N°1 Exhaust pipe Ø80
- N°1 Wall sealing plate

1.16 CONCENTRIC HORIZONTAL KIT INSTALLATION

Type C configuration, sealed chamber and fan assisted

The position of the terminal (in terms of distances from openings, overlooking buildings, floor, etc.) must be in compliance with the regulations in force.

This terminal is connected directly to the outside of the building for air intake and flue gas exhaust.

The horizontal kit can be installed with the rear, right side, left side or front outlet.

For installation with frontal outlet, one must use the fixing plate and a concentric bend coupling in order to ensure sufficient space to carry out the tests required by law upon commissioning.

External grid

Both the $\varnothing 60/100$ and $\varnothing 80/125$ intake/exhaust terminal, if properly installed, is pleasant to look at on the outside of the building.

Make sure that the external silicone wall sealing plate is properly inserted in the wall.



For correct functioning of the system the terminal with grid must be installed correctly ensuring that, the "high" indication present on the terminal is respected on installation.

Mounting the horizontal intake-exhaust kit $\varnothing 60/100$ (Fig. 14)

1. Install the bend with flange (2) on the central hole of the boiler, positioning gasket (1) with the circular projections downwards in contact with the boiler flange, and tighten using the screws present in the kit.
2. Fit the $\varnothing 60/100$ (3) concentric terminal pipe with the male side (smooth) to the female side of the bend (2) up to the end stop, making sure that the internal and external wall sealing plates have been fitted; this will ensure sealing and joining of the elements making up the kit.

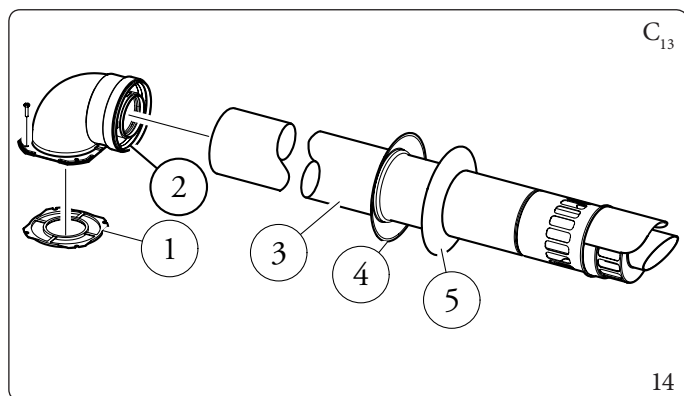

The kit includes (Fig. 14):

- N°1 Gasket (1)
- N°1 Concentric bend $\varnothing 60/100$ (2)
- N°1 Int./exhaust concentric terminal $\varnothing 60/100$ (3)
- N°1 Internal wall sealing plate (4)
- N°1 External wall sealing plate (5)

Extensions for $\varnothing 60/100$ horizontal kit. Kit assembly (Fig. 15)

The kit with this configuration can be extended up to a max. horizontal length of 12.9 m including the terminal with grid and excluding the concentric bend leaving the boiler.

This configuration corresponds to a resistance factor of 100.

In this case the special extensions must be requested.

Immergas also provides a $\varnothing 60/100$ simplified terminal, which in combination with its extension kits allows you to reach a maximum extension of 11.9 metres.

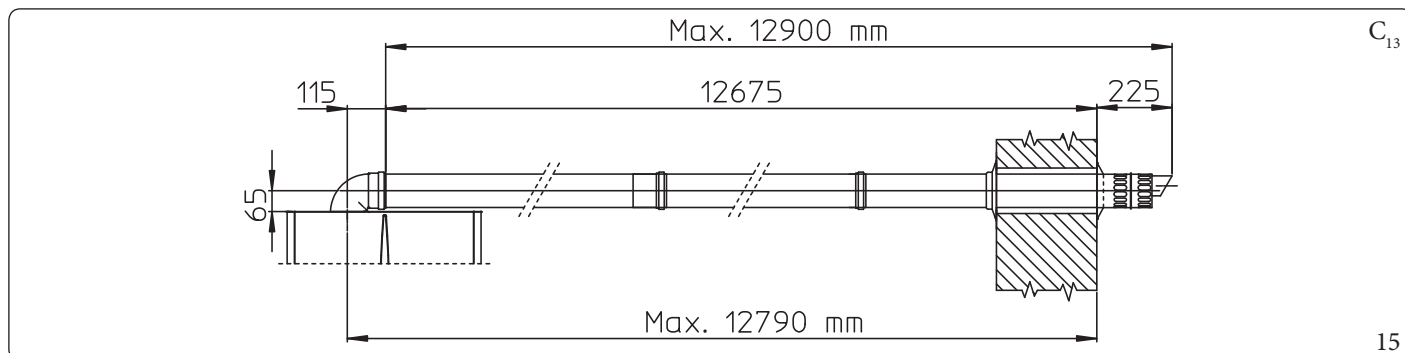

Mounting the horizontal intake-exhaust kit Ø 80/125 (Fig. 16)

To install the kit Ø 80/125 one must use the flanged adaptor kit in order to install the flue system Ø 80/125.

1. Install the flanged adaptor (2) on the central hole of the boiler, positioning gasket (1) with the circular projections downwards in contact with the boiler flange, and tighten using the screws contained in the kit.
2. Engage the bend (3) with the male side (smooth) to the end stop on the adaptor (1).
3. Fit the Ø 80/125 (5) concentric terminal pipe with the male side (smooth) to the female side of the bend (4) (with lip seals) up to the end stop, making sure that the internal (6) and external wall sealing plates (7) have been fitted; this will ensure sealing and joining of the elements making up the kit.

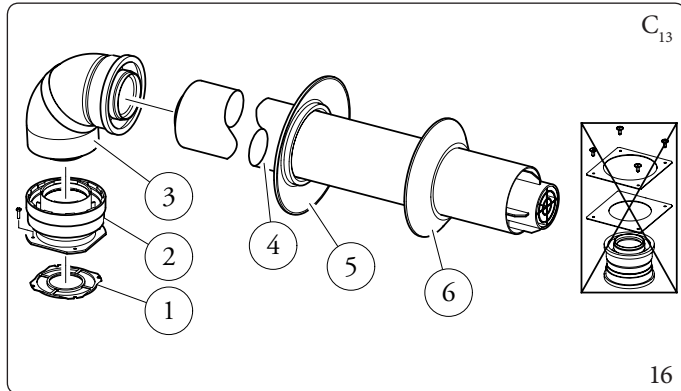

The adapter kit includes (Fig. 16):

- N°1 Gasket (1)
- N°1 Adapter Ø 80/125 (2)

The Kit Ø 80/125 includes (Fig. 16):

- N°1 Concentric bend Ø 80/125 at 87° (3)
- N°1 Int./exhaust concentric terminal Ø 80/125 (4)
- N°1 Internal wall sealing plate (5)
- N°1 External wall sealing plate (6)

The remaining kit components must not be used

Extensions for Ø 80/125 horizontal kit. Kit assembly (Fig. 17)

The kit with this configuration can be extended up to a max. length of 32 m, including the terminal with grid and excluding the concentric bend leaving the boiler.

If additional components are assembled, the length equivalent to the maximum allowed must be subtracted.

In this case the special extensions must be requested.

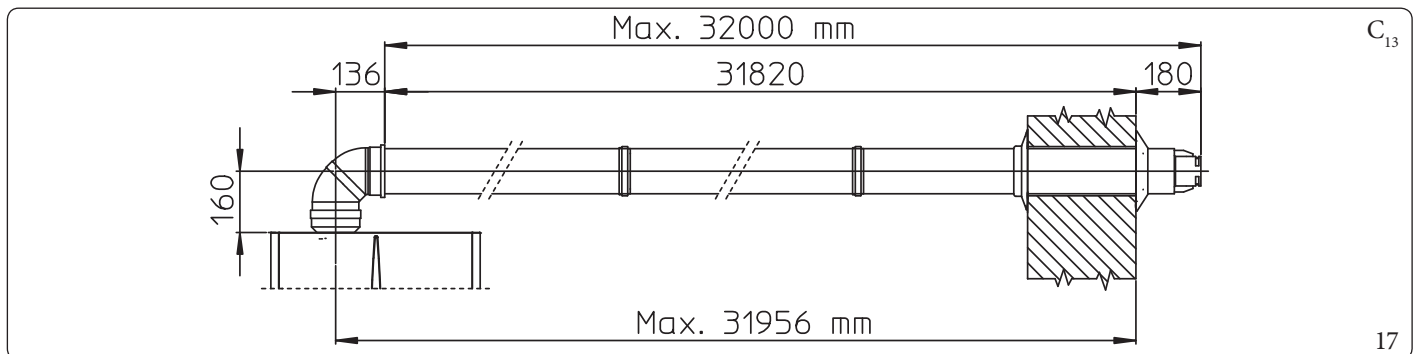

1.17 CONCENTRIC VERTICAL KIT INSTALLATION

Type C configuration, sealed chamber and fan assisted

Concentric vertical intake and exhaust kit.

This vertical terminal is connected directly to the outside of the building for air intake and flue gas exhaust.



The vertical kit with aluminium tile enables installation on terraces and roofs with a maximum slope of 45% (approx. 25°) and the height between the terminal cap and half-shell (374 mm for Ø 60/100 and 260 mm for Ø 80/125) must always be observed.

Mounting the vertical kit with aluminium tile Ø 60/100 (Fig. 18)

1. Install the concentric flange (2) on the central hole of the boiler, positioning gasket (1) with the circular projections downwards in contact with the boiler flange.

Imitation aluminium tile installation:

2. Replace the tiles with the aluminium sheet (4), shaping it to ensure that rainwater runs off.
3. Position the fixed half-shell (6) on the aluminium tile.
4. Insert the intake-exhaust pipe (5).
5. Fit the Ø 60/100 concentric terminal pipe with the male side (5) (smooth) into the flange (2) up to the end stop, making sure that the wall sealing plate has been fitted (3); this will ensure sealing and joining of the elements making up the kit.



When the boiler is installed in areas where very cold temperatures can be reached, a special anti-freeze kit is available that can be installed as an alternative to the standard kit.

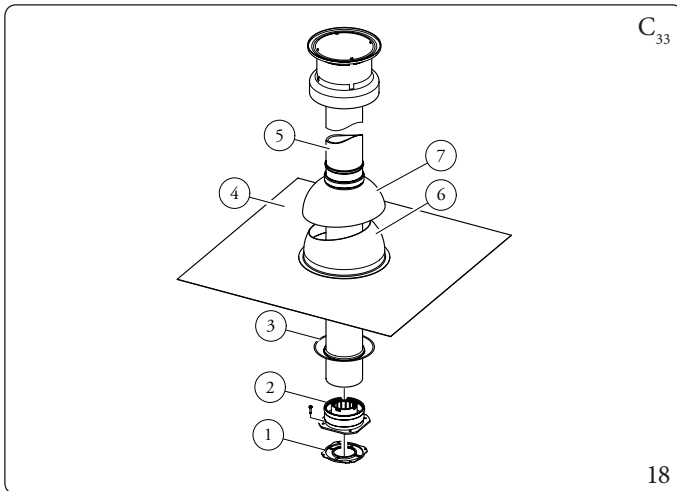

The kit includes (Fig. 18):

- N°1 Gasket (1)
- N°1 Female concentric flange (2)
- N°1 Wall sealing plate (3)
- N°1 Aluminium tile (4)
- N°1 Concentric intake/exhaust pipe Ø 60/100 (5)
- N°1 Fixed half-shell (6)
- N°1 Mobile half-shell (7)

Extensions for Ø 60/100 vertical kit (Fig. 19)

The kit with this configuration can be extended up to a max. vertical straight length of 14.4 m including the terminal. This configuration corresponds to a resistance factor of 100. In this case specific extensions must be requested.

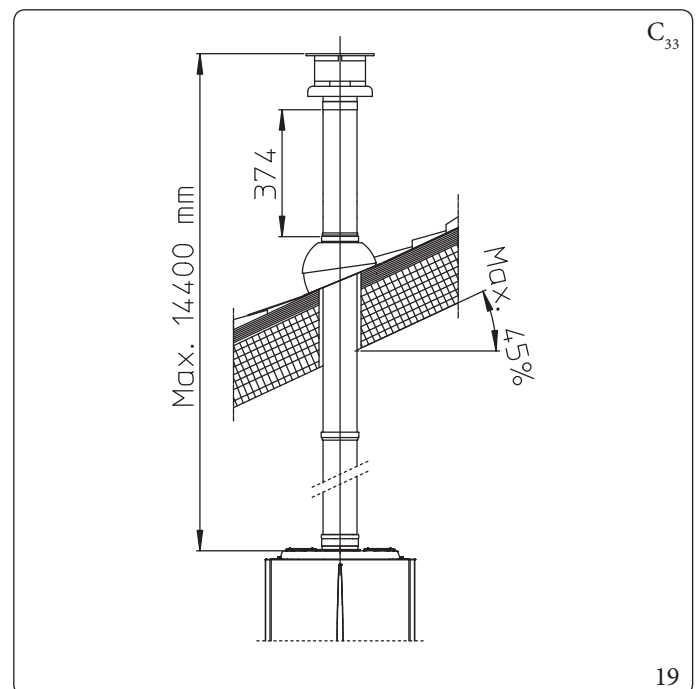

Mounting the vertical kit with aluminium tile Ø 80/125 (Fig. 20)

 To install the kit Ø 80/125 one must use the flanged adapter kit in order to install the flue system Ø 80/125.

1. Install the flanged adaptor (2) on the central hole of the boiler, positioning gasket (1) with the circular projections downwards in contact with the boiler flange.

Imitation aluminium tile installation:

2. Tighten the concentric flange with the screws in the kit.
3. Replace the tiles with the aluminium sheet (4), shaping it to ensure that rainwater runs off.
4. Position the fixed half-shell (5) on the aluminium tile;
5. Insert the intake-exhaust terminal (7);
6. Fit the Ø 80/125 concentric terminal pipe with the male side (smooth) to the female side of the adapter (1) (with lip seals) up to the end stop, making sure that the wall sealing plate (3) has been fitted; this will ensure sealing and joining of the elements making up the kit.

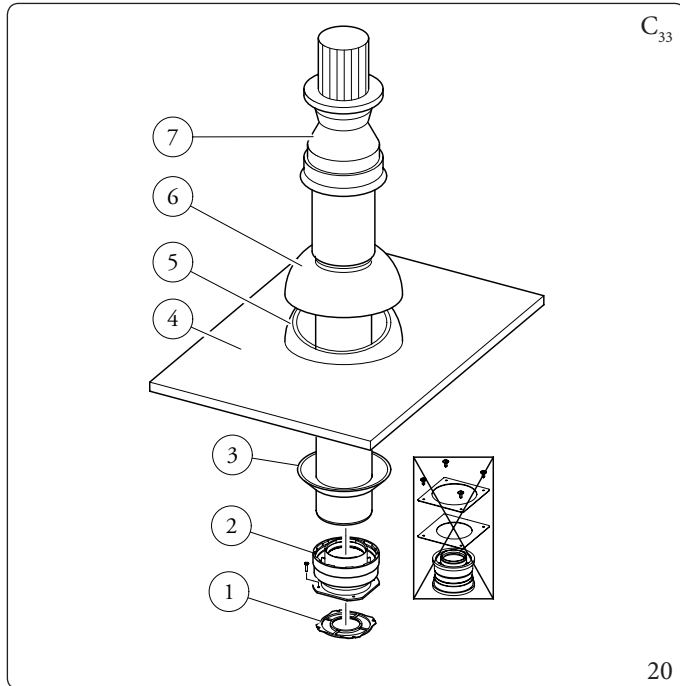

The adapter kit includes (Fig. 20):

- N°1 Gasket (1)
- N°1 Adapter Ø 80/125 (2)

The Kit Ø 80/125 includes (Fig. 20):

- N°1 Wall sealing plate (3)
- N°1 Aluminium tile (4)
- N°1 Fixed half-shell (5)
- N°1 Mobile half-shell (6)
- N°1 Concentric intake/exhaust pipe Ø 80/125 (7)

The remaining kit components must not be used

INSTALLER

USER

MAINTENANCE TECHNICIAN

TECHNICAL DATA

Extensions for Ø 80/125 vertical kit (Fig. 21)

The kit with this configuration can be extended to a max. straight vertical length of 32 m, including the terminal. If additional components are assembled, the length equivalent to the maximum allowed must be subtracted. In this case specific extensions must be requested.

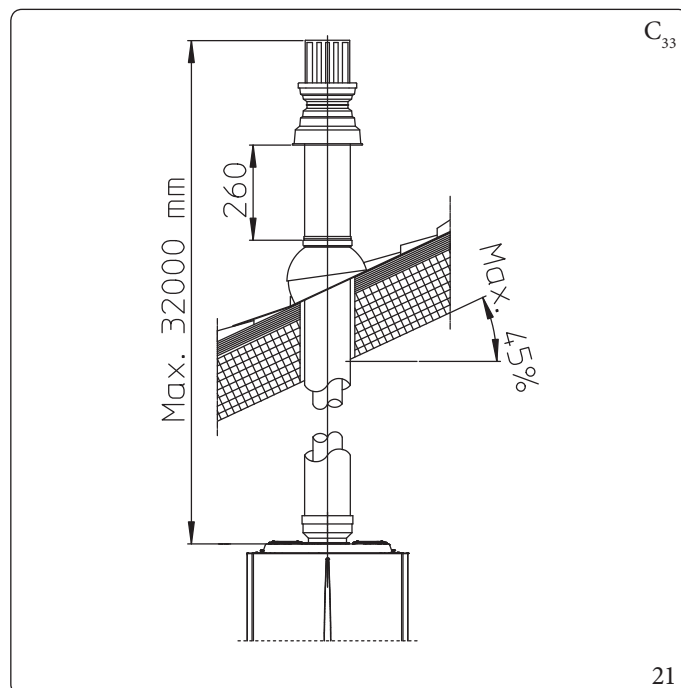

1.18 SEPARATOR KIT INSTALLATION

Type C configuration, sealed chamber and fan assisted, separator kit Ø 80/80

This kit allows air to come in from outside the building and the exhaust to exit from the chimney, flue or intubated duct through divided flue exhaust and air intake pipes.

Combustion products are expelled from pipe (S) (in plastic, so as to resist acid condensate).

Air is taken in through duct (A) for combustion (this is also in plastic).

The intake pipe (A) can be installed either on the right or left hand side of the central exhaust pipe (S).

Both ducts can be routed in any direction.

Mounting the separator kit Ø 80/80 (Fig. 22):

1. Install the flange (4) on the central hole of the boiler, positioning gasket (1) with the circular projections downwards in contact with the boiler flange.
2. Tighten with the hexagonal head and flat point screws provided in the kit.
3. Replace the flat flange present in the lateral hole with respect to the central one (according to needs) with the flange (3), positioning the gasket (2) already present in the boiler
4. Tighten with the supplied self-tapping screws with drill bit.
5. Fit the bends with male side (smooth) (5) in the female side of the flanges (3 and 4).
6. Fit the intake terminal (6) with the male side (smooth) in the female side of the bend (5) up to the end stop, ensuring that the internal and external wall sealing plates are fitted
7. Fit the exhaust pipe (9) with the male end (smooth) to the female end of the bend (5) up to the end stop; making sure that the internal wall sealing plate has been fitted, this will ensure sealing and joining of the elements making up the kit.

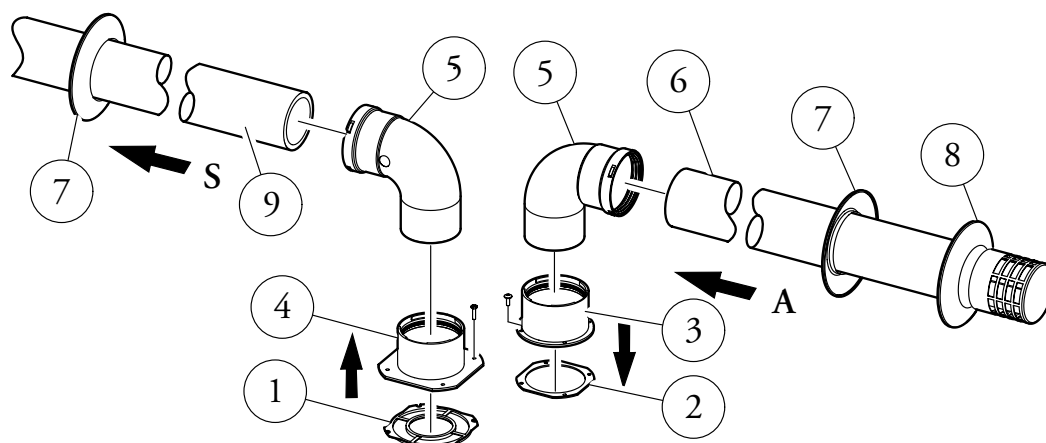

22

The kit includes (Fig. 22):

- N°1 Exhaust gasket (1)
- N°1 Flange gasket (2)
- N°1 Female intake flange (3)
- N°1 Female exhaust flange (4)
- N°2 Ø80 90° bend (5)
- N°1 Intake terminal Ø80 (6)

- N°2 Internal wall sealing plates (7)
- N°1 External wall sealing plate (8)
- N°1 Exhaust pipe Ø80 (9)

* to complete C₅₃ configuration, also provide for a "green range" roof discharge terminal. The configuration on walls opposite the building is not allowed.

Installation clearances (Fig. 23)

The minimum installation clearance measurements of the Ø 80/80 separator terminal kit have been stated in some limit conditions.

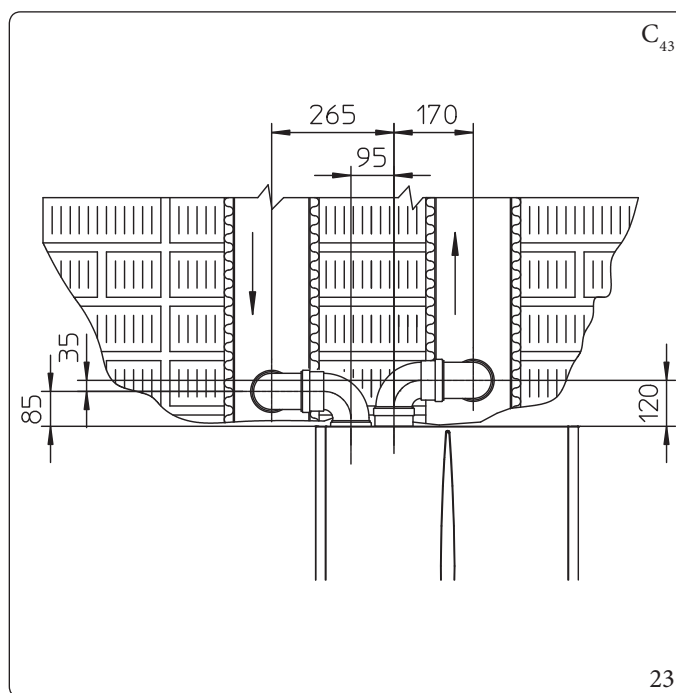

23

Extensions for separator kit Ø 80/80

The maximum vertical straight length (without bends) that can be used for Ø 80 intake and exhaust pipes is 41 metres, regardless from whether they are used for intake or exhaust.

The maximum horizontal straight length (with bend in suction and in exhaust) that can be used for Ø 80 intake and exhaust pipes is 36 metres, regardless from whether they are used for intake or exhaust.

Please note the type of installation C₄₃ must be done with a natural draught flue.



To favour the removal of possible condensate forming in the exhaust pipe, tilt the pipes towards the boiler with a minimum slope of 1.5% (Fig. 24)

1.19 C9 ADAPTOR KIT INSTALLATION

This kit allows an Immergas boiler to be installed in "C₉₃" configuration, with combustion air intake directly from the shaft where the flue gas exhaust is, obtained by means of a ducting system.

System composition

The system must be combined with the following components (sold separately) to be functional and complete:

- kit C₉₃ Ø 100 or Ø 125 version;
- rigid ducting Ø 60 and Ø 80 and flexible Ø 50 and Ø 80 kit;
- flue exhaust kit Ø 60/100 or Ø 80/125 configured according to the installation and type of boiler.

Mounting the C₉ adaptor kit (Fig. 26)



(Version Ø 125 only) before assembly check the gaskets are in the right position.

In the event component lubrication (already carried out by the manufacturer) is not sufficient, remove the residual lubricant using a dry cloth, then to ease fitting coat the parts with common or industrial talc.



To favour the removal of possible condensate forming in the exhaust pipe, tilt the pipes towards the boiler with a minimum slope of 1.5% (Fig. 24)

1. Mount the components of kit "C₉" on the door (A) of the ducting system (Fig. 26).
2. (Version Ø 125 only) mount the flanged adaptor (11) interposing the concentric gasket (10) on the boiler, fitting it with the screws (12).
3. Mount the ducting system as described in the relative instructions sheet.
4. Calculate the distances between the boiler drain and the bend of the ducting system.
5. Prepare the boiler flue system, making sure that the internal pipe of the concentric kit is fitted up to the end stop in the ducting system curve (Quota "X" Fig. 27), whereas the external pipe must reach the end stop of the adaptor (1).
6. Mount the cover (A) complete with adaptor (1) and caps (6) on the wall.
7. Assemble the flue system to the ducting system.

Once all components have been assembled properly, the exhaust flue gas will be expelled via the ducting system; the combustion air for normal boiler operation will be aspirated directly by the shaft (Fig. 27).

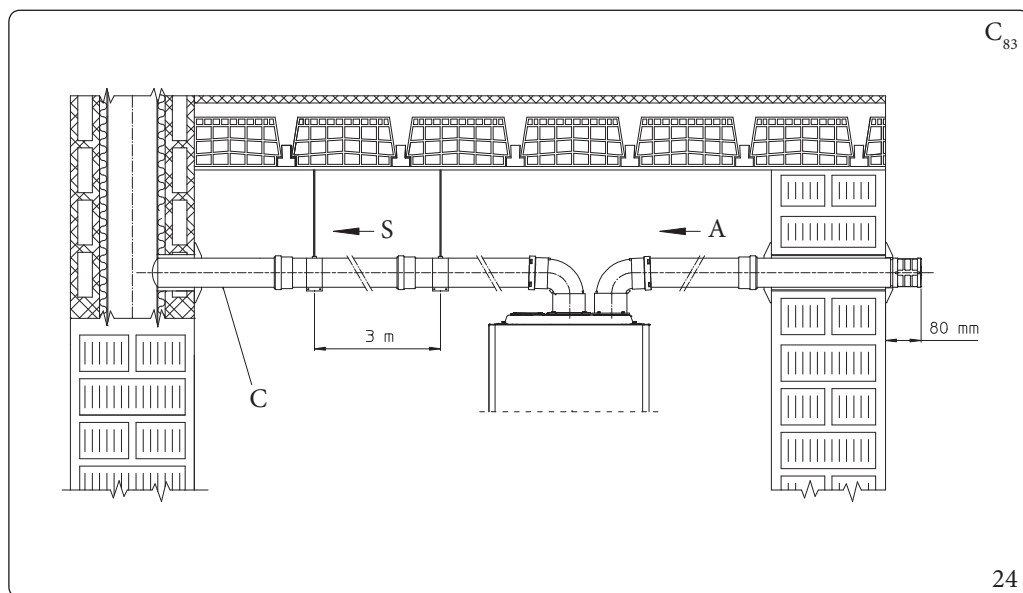

Key (Fig. 24):

- A - Intake
- C - Minimum gradient 1.5 %
- S - Exhaust

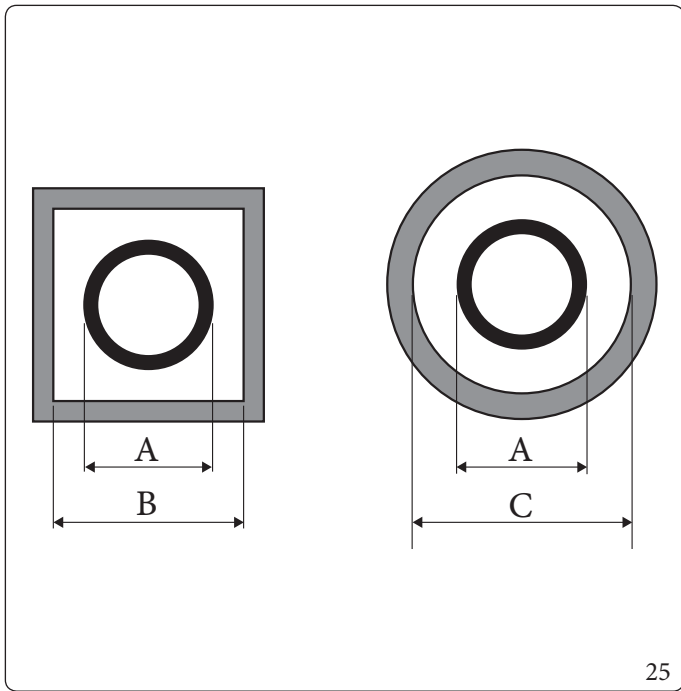

25

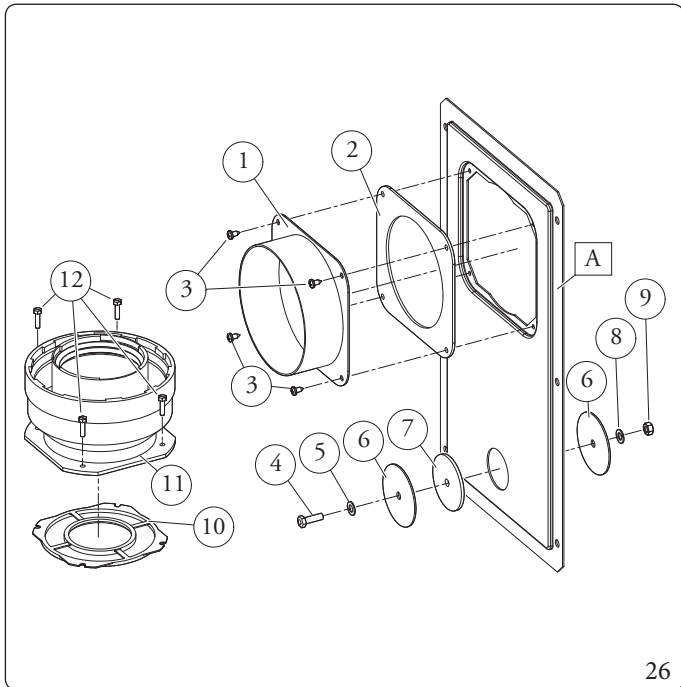

26

Ducting	ADAPTOR (A) mm	SHAFT (B) mm	SHAFT (C) mm
Ø 60 Rigid	66	106	126
Ø 50 Flexible	66	106	126
Ø 80 Rigid	86	126	146
Ø 80 Flexible	103	143	163

The adaptor kit includes (Fig. 26):

- N°1 Door adaptor Ø 100 or Ø 125 (1)
- N°1 Door gasket made of neoprene (2)
- N°4 Screws 4.2x9 AF (3)
- N°1 Hex headed screw M6x20 (4)
- N°1 Flat nylon washer M6 (5)
- N°2 Door hole closure metal-sheet plate plug (6)
- N°1 Pluggasket made of neoprene (7)
- N°1 Toothed washer M6 (8)
- N°1 Nut M6 (9)
- N°1 (kit Ø 80/125) Concentric gasket Ø 60/100 (10)
- N°1 (kit Ø 80/125) Flanged adapter Ø 80/125 (11)
- N°4 (kit Ø 80/125) Hex head screws M4 x 16 slotted screwdriver (12)
- N°1 (kit Ø 80/125) Bag of lubricating talc

Supplied separately (Fig. 26):

- N°1 Ducting kit door (A)

Technical data

The dimensions of the shafts must ensure a minimum gap between the outer wall of the smoke duct and the inner wall of the shaft: 30 mm for circular section shafts and 20 mm in the event of a square section shaft (Fig. 25).

Maximum 2 changes of direction are allowed on the vertical section of the flue system with a maximum clearance angle of 30° with respect to the vertical.

The maximum vertical extension using a Ø 60 ducting system is 22 m, the maximum extension includes 1 bend Ø 60/100 at 90°, 1 m of horizontal pipe Ø 60/100, 1 x 90° ducted bend Ø 60 and the roof terminal for ducting.

The maximum vertical extension using a Ø 80 rigid ducting system is 28 m, the maximum extension includes 1 adapter from Ø 60/100 to Ø 80/125, 1 bend Ø 80/125 of 87°, 1 m of pipe Ø 80/125 in horizontal, 1 x 90° ducted bend Ø 80 and the roof terminal for ducting.

To determine the C₉₃ flue system in configurations other than that described (Fig. 27) one must consider the following head losses:

- 1 m of concentric pipe Ø 80/125 = 1.8 m of rigid ducted pipe Ø 80 and 0.7 m of flexible ducted pipe Ø 80;
- 1 curve Ø 80 of 87° = 2.1 m of rigid ducted pipe Ø 80 and 0.9 m of flexible ducted pipe Ø 80.

Consequently one must subtract the equivalent length of the part added to the 28 m available.

INSTALLER

USER

MAINTENANCE TECHNICIAN

TECHNICAL DATA

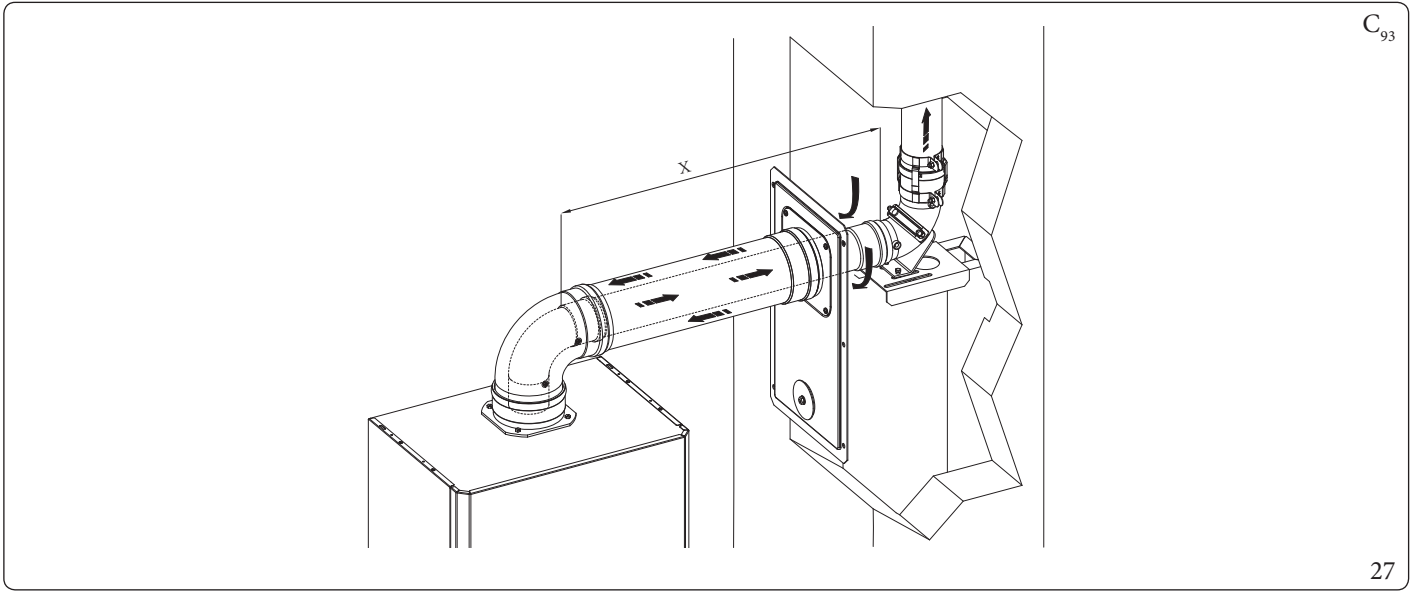

C₉₃

27

1.20 C15 CONFIGURATION CONCENTRIC KIT

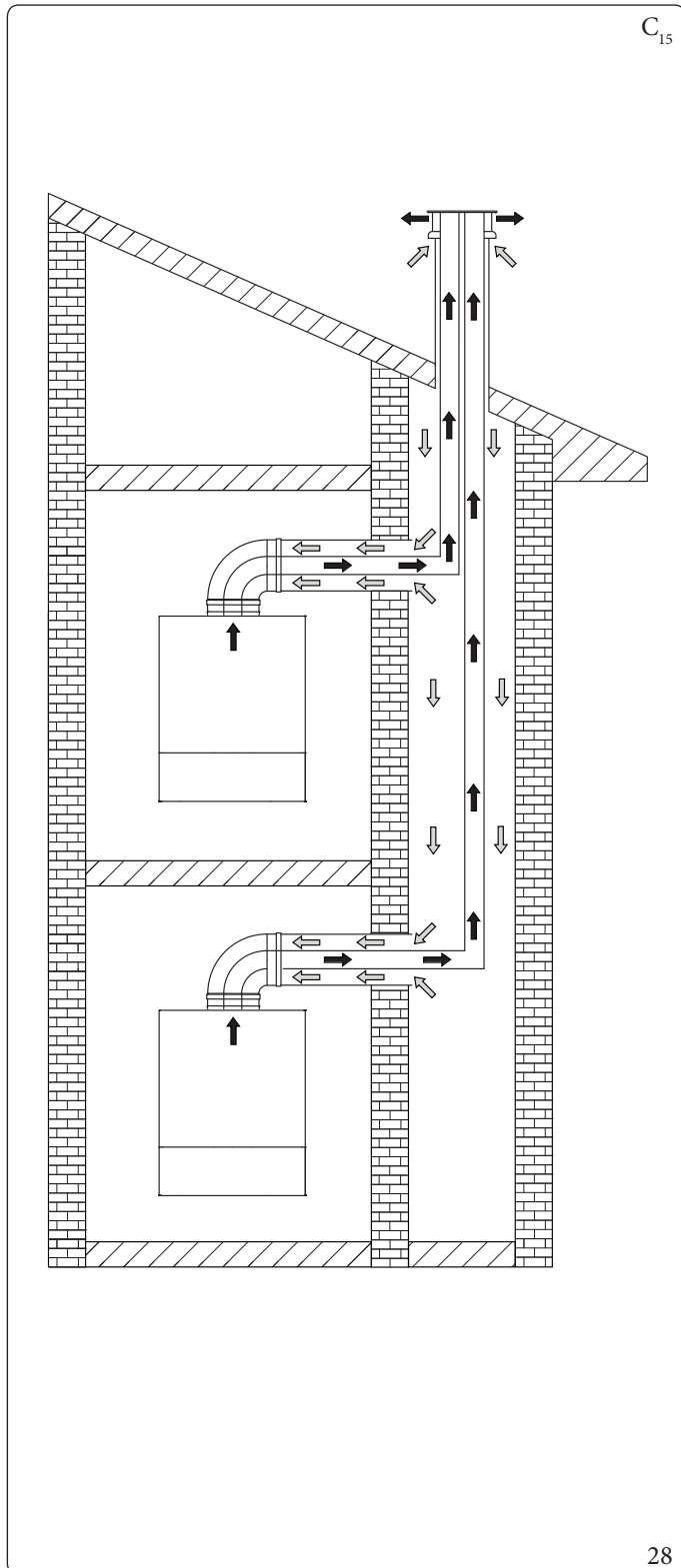

Installation in "C₁₅" configuration of an Immergas boiler, makes it possible to intake combustion air directly from the shaft where the flue gas exhaust is present in the dedicated flue.

Information for C15 installations

The boiler is suitable for operating in a C(15)3 or C(15)3X system, correctly sized by a thermotechnical designer.

The roof terminal, which is an integral part of the project, must also meet the legislative and regulatory obligations prescribed for this component. In particular, it must ensure that the degree of recirculation of the flue gas is always below 10%.

The common supply shaft must be sized so that, in combination with the intake part of the roof terminal, a vacuum greater than 5 Pa is not generated at the point of the shaft where the boiler draws the combustion air from the shaft itself, when the boiler works at maximum heat output and the entire multiple ducting system works at maximum design power.

If the single terminal complies with the following head losses conditions at the maximum boiler heat input:

Model	Pa
VICTRIX ZEUS SUPERIOR 25	5
VICTRIX ZEUS SUPERIOR 30 and 35	10

in compliance with the conditions described above, the maximum extensions that can be achieved in the shaft are those defined in this manual with C93 configuration, using the same boiler settings.

INSTALLER

USER

MAINTENANCE TECHNICIAN

TECHNICAL DATA

1.21 CONCENTRICKIT C10 CONFIGURATION (Ø 80/125)

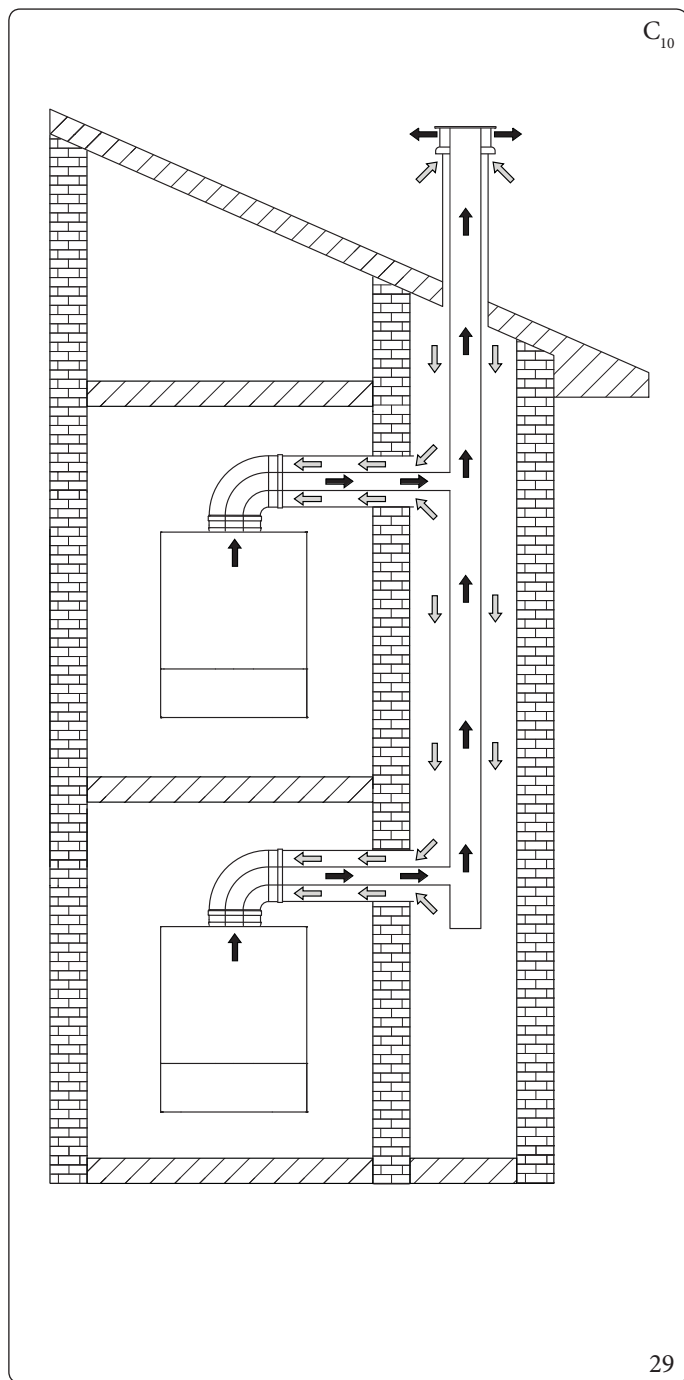

Installation in "C₁₀" configuration of an Immergas boiler (only permitted with approved original flue), makes it possible to intake combustion air directly from the shaft where the flue gas exhaust is present in the collective flue.



Coupling to the shaft for intake is possible with male flue Ø 125 or Ø 125 cut female.

The collective flue coupling for the exhaust is possible with female Ø 80 flue with gasket.

(Fig. 31)

Concentric kit assembly in C₁₀ type configuration (Fig. 31)



To favour the removal of possible condensate forming in the exhaust pipe, tilt the pipes towards the boiler with a minimum slope of 1.5% (Fig. 30)

1. Mount the flanged adaptor (14) interposing the concentric gasket (15) on the boiler, fitting it with the screws (13).
2. Insert the non-return valve kit on flue gas Ø 80 in the flanged adaptor, taking care to remove the spacer Ø 80 th. 5 mm.



Make sure to fill the flue gas non-return valve siphon with water

3. Fit the Ø 125 extension in the flanged adaptor.
4. Calculate the distances between boiler exhaust and connection to the collective flue.
5. Prepare the boiler flue system, making sure that the internal pipe of the concentric kit is fitted up to the end stop in the collective flue.



Before mounting it, ensure that the gaskets are in the correct position.

In the event component lubrication (already carried out by the manufacturer) is not sufficient, remove the residual lubricant using a dry cloth, then to ease fitting coat the parts with common or industrial talc.

6. Mount the cover (A) complete with adaptor (1) and caps (6) on the wall.

7. Assemble the flue to the collective flue exhaust system.

Once all components have been assembled properly, the exhaust flue gas will be expelled in the collective flue, the combustion air for normal boiler operation will be aspirated directly by the shaft (Fig. 27).

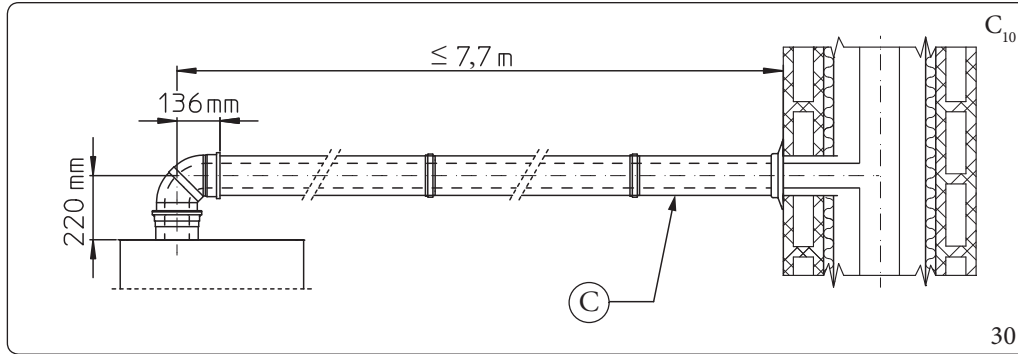

Key (Fig. C₁₀30):

C - Minimum gradient 1.5 %

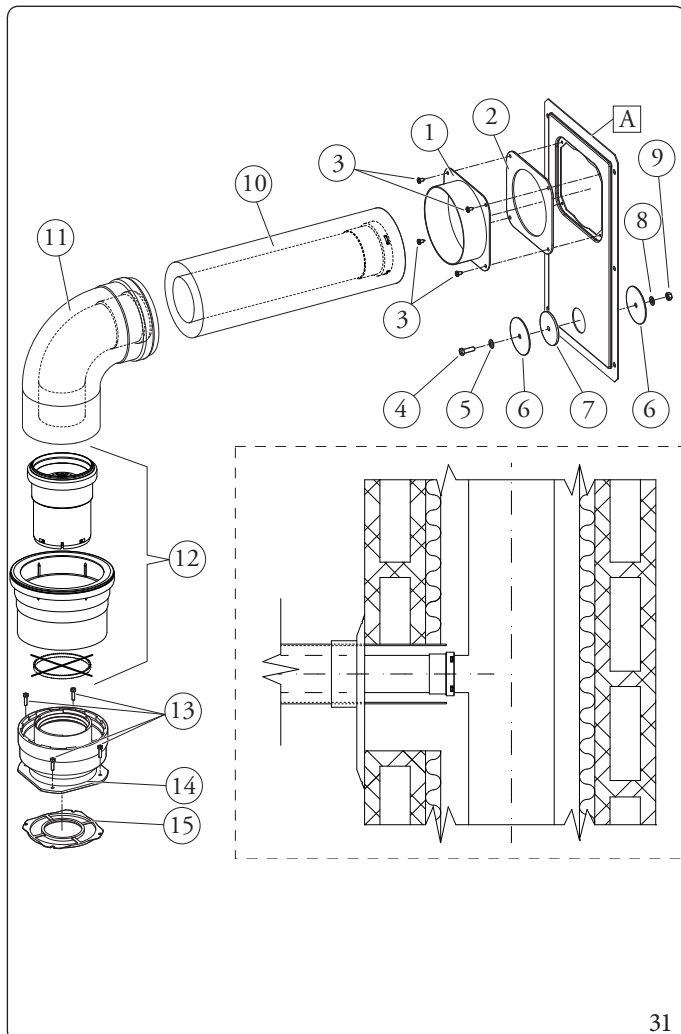

Key (Fig. 31):

The C9 adaptor kit includes:

- No.1 Door adaptor Ø 100 or Ø 125 (1)
- No.1 Door gasket made of neoprene (2)
- No.4 Screws 4.2x9 ST (3)
- No.1 Hex headed screw M6x20 (4)
- No.1 Flat nylon washer M6 (5)
- No.2 Door hole closure metal-sheet plate plug (6)
- No.1 Plug gasket made of neoprene (7)
- No.1 Toothed washer M6 (8)
- No.1 M6 nut (9)

The Ø 80/125 extension pipe kit includes:

- No.1 Extension pipe unit Ø 80/125 (10)

The bend kit Ø 80/125 includes:

- No.1 Concentric bend Ø 80/125 at 87° (11)

The kit non-return valve on flue gas Ø 80 (12) includes:

- No.1 Gasket / Seal Ø 80
- No.1 Non-return valve on flue gas Ø 80
- No.1 Extension Ø 125
- No.1 Spacer Ø 80 th. 5 mm (to be excluded for this configuration)
- No.1 Information sticker

The adaptor kit includes:

- No.4 (kit Ø 80/125) Hex headed screws M4 x 16 slotted screwdriver (13)
- No.1 (kit Ø 80/125) Flanged adapter Ø 80/125 (14)
- No.1 (kit Ø 80/125) Concentric gasket (15)

Supplied separately (Fig. 31):

- No.1 Ducting kit door (A)

1.22 CONFIGURATION C10 - C12 SEPARATOR KIT (Ø 80/80)

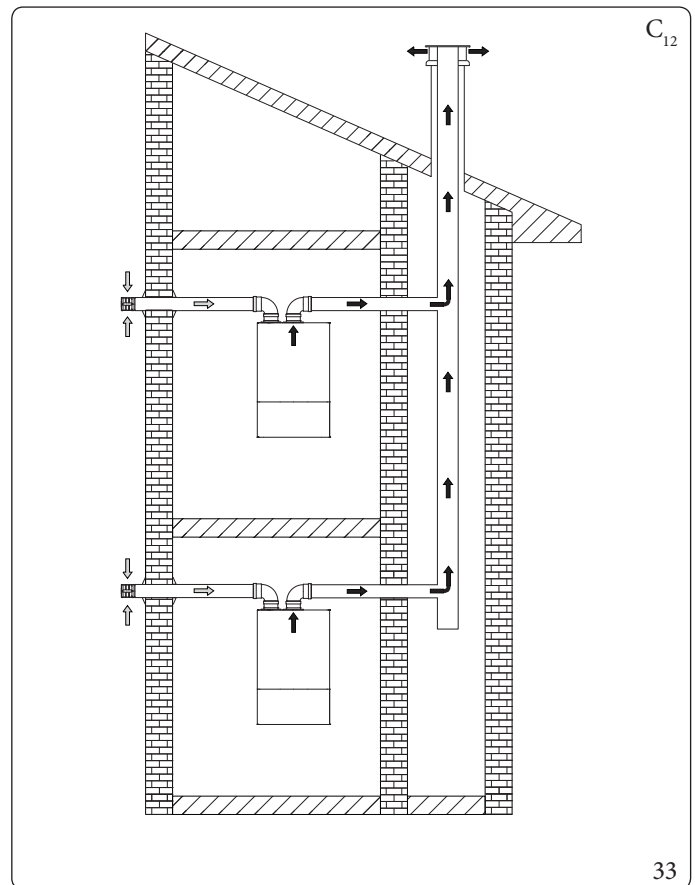
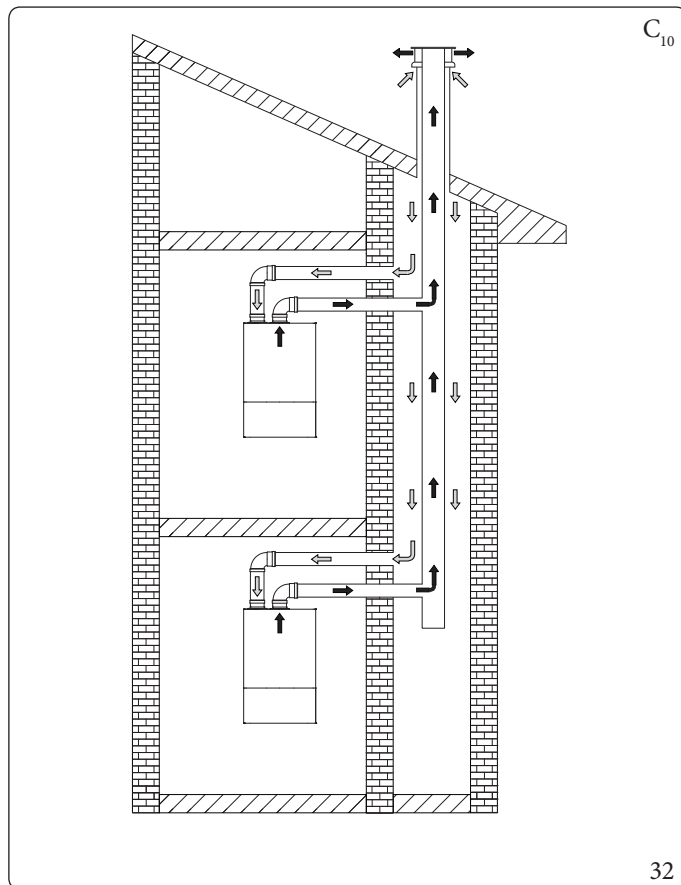

This configuration (allowed only with the approved original flue), makes it possible to suck the air outside the home or directly from the shaft where the flue gas exhaust is present and the evacuation of the flue gas itself inside a collective flue.



C10 (Fig. 32):

Coupling to the shaft for intake is possible with male flue Ø 80 or Ø 80 cut female.

C10 - C12 (Fig. 32 - 33)

The collective flue coupling for the exhaust is possible with female Ø 80 flue with gasket.

Mounting the separator kit Ø 80/80 (Fig. 34):

Install the discharge flange (4) on the boiler sample point flange, positioning the relative gasket (1) with the circular projections downwards in contact with the boiler flange, and tighten using the hex screws with flat tip contained in the kit.

1. Remove the extension Ø 125 from the non-return valve kit on the flue gas, insert the spacer Ø 80 th. 5 mm inside the flue gas exhaust flange and then insert the non-return valve on the flue gas Ø 80.
2. Remove the flat flange present in the intake hole and replace it with the intake flange (3), positioning the gasket (2) contained in the separator kit Ø 80/80 and tighten using the supplied self-threading screws.
3. Fit the bends with male side (smooth) (5) in the female side of the flanges (3 and 4).
4. For the intake from shaft (C10) or from a common intake duct, connect the Ø 80 intake ducts (6) to the bend (5), making sure to have already inserted the internal wall sealing plate (7). For the wall intake (C12), fit the male end (smooth) of the intake terminal (6) into the female end of the bend (5) up to the end stop, making sure to have already inserted the relative internal and external wall sealing plate (7) (8).



Make sure to fill the flue gas non-return valve siphon with water

5. Connect the Ø 80 drain pipe making sure to have already inserted the internal wall sealing plate (7) inside the end section of the pipe.



For maximum extension of the Ø 80/80 terminals and for the installation dimensions, refer to the figures (Fig. 36 - 35)

For the development of the exhaust terminals, a maximum resistance of 19.5 is considered; to calculate the resistance factor, refer to the tables on pages 21 and 22.

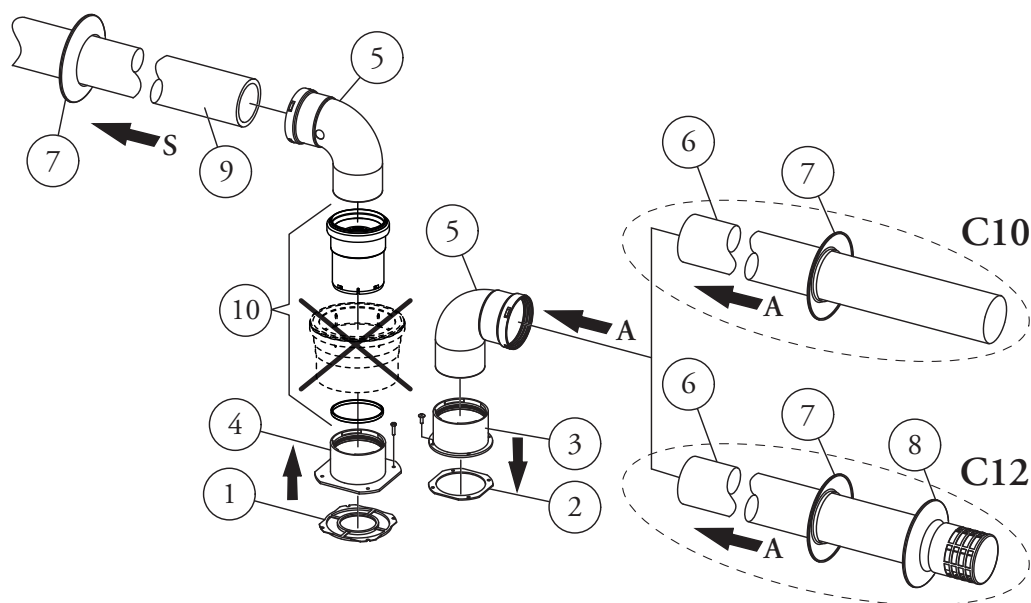

34

The kit includes (Fig. 34):

No.1 Exhaust gasket (1)

No.1 Flange gasket (2)

No.1 Female intake flange (3)

No.1 Female exhaust flange (4)

No.2 Bend 90° Ø 80 (5)

No.1 Extension Ø 80 (6) (C10 only)

No.1 Intake terminal Ø 80 (6) (C12 only)

No.2 Internal wall sealing plates (7)

1 External wall sealing plate (8) (C12 only)

No.1 Exhaust pipe Ø 80 (9)

No.1 (flue gas non-return valve kit Ø 80) (10)

N.B.: eliminate the extension Ø 125

The configuration on walls opposite the building is not allowed.

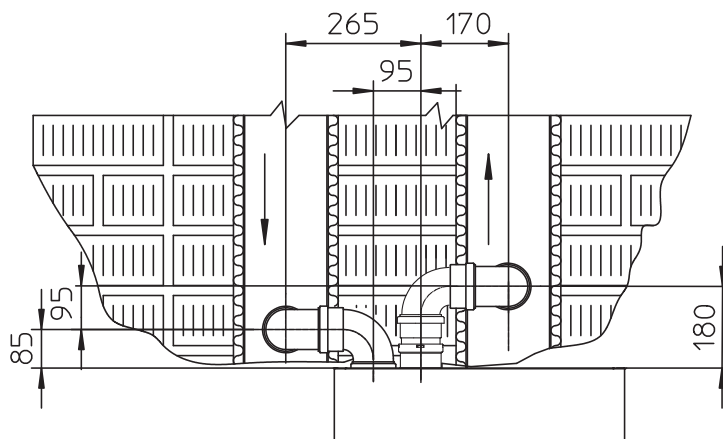
C₁₀

35

INSTALLER

USER

MAINTENANCE TECHNICIAN

TECHNICAL DATA

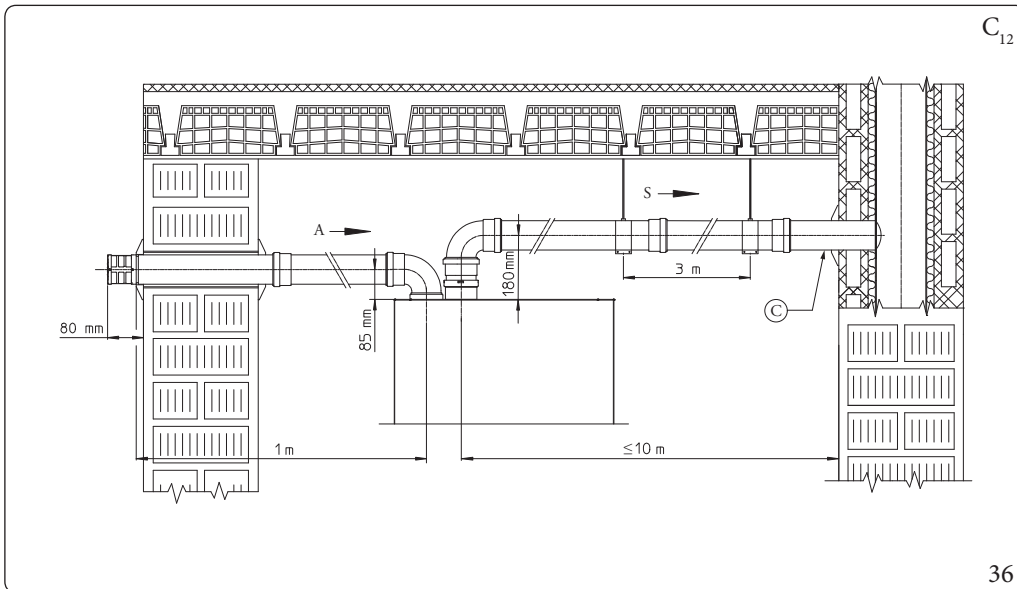

Key (Fig. 36):

- A - Intake
- C - Minimum gradient 1.5 %
- S - Exhaust

In the C(10) and C(12) installation, the boiler flue exhaust must be fitted with a $\varnothing 80$ flue gas non-return valve kit, consisting of the valve itself with instructions, specification and relative sticker with additional safety information (Fig. 31):

Information for C10 installations

The boiler is suitable for operation in a C(10) system and only with the supply of methane gas (2H and 2E categories).

The boilers are developed to operate on collective pressurised flues with a safety pressure at the minimum heat input of 25 Pa and a safety pressure at the maximum heat input of 100 Pa.



Calibration operations are not permitted in the boilers installed in type C(10) flue systems, as the CO₂ emission levels are affected by the operating pressures induced in the collective flue, with particular reference to the minimum heat flow rate or any recirculation phenomena induced by the flue system.

The factory setting must be used in these flue systems, except for the "Min" parameter which must be set to 1.

The boiler must be connected to a flue system designed by a heating engineer in compliance with the local regulation in force.

The collective flue system must be suitably sized to allow the boiler to operate with the following specifications with which it was designed:

- the maximum pressure, when n-1 boiler is working at maximum heat input (with n= number of total boilers connected or that can be connected to the same collective duct), and a boiler works at minimum heat input, is 25 Pa;
- flue gas mass at maximum heat input;
- flue gas mass at minimum heat input;
- the minimum pressure difference allowed between the combustion product outlet and the combustion air inlet is -200 Pa (- 400 Pa for C12) including -100 Pa (-300 Pa C12) of pressure generated by wind;
- the duct must have been sized with a nominal temperature of the combustion products of 25°C.
- the maximum allowed recirculation rate for wind action is 10%;
- the common flue must be certified to admit an overpressure of at least 200 Pa;
- no draught-breaker devices must be provided in the duct system.

In particular, at the coupling point to the pressurised collective flue, a plate must be visible showing at least the following technical information:

- the name and trademark of the common flue gas pipe manufacturer;
- suitability to work with C(10) certified boilers;
- the maximum flue gas mass value allowed in kg/h;
- the dimensions of the common duct part;



The openings for combustion air and the inlet of combustion products of the pressurised collective flue must be closed and their tightness must be checked when the boiler is disconnected.

The boiler connection to the pressurised collective flue must be made as instructed, without exceeding the specific maximum extensions stated.

The boiler flue gas duct must be tilted a few degrees towards the boiler, to facilitate the evacuation of condensate.



The boiler flue gas outlet must be installed with the flue gas non-return valve kit, which ensures correct operation of the appliance and facilitates its maintenance operations.

Furthermore, the safety sticker must be affixed on the front casing. This sticker is contained in the appropriate Kit C(10) C(12), which contains the additional exhaust flue gas non-return valve, necessary for the pressurised collective flues.

The sticker indicates the following information in language:



It is advisable to affix the sticker in a clearly visible position on the front casing.

- The installation of this boiler is of type C(10) or C(12).
- Before proceeding with maintenance operations, it is crucial to read the instructions provided in the manual.
- Parameter “Min” relating to the fan rotation speed must be set to 1.



When the sealed chamber is opened, combustion products may escape even when the boiler is turned off.

Maximum Immergas flue duct extensions for installation in collective flue

- Flue ducts Ø 80/80: 10 metres + 1 metre intake terminal
- Flue ducts Ø 80/125: 7.7 metres

1.23 DUCTING OF FLUES OR TECHNICAL SLOTS

Ducting is an operation through which, via the introduction of one or more relevant pipes, one achieves a system for the evacuation of the combustion products of a gas appliance, made up from the coupling of an existing or new ducting pipe with a chimney, flue or technical slot (also in new buildings) (Fig. 37).

Ducting requires ducts declared to be suitable for the purpose by the manufacturer, following the installation and user instructions, provided by the manufacturer and the requirements of the regulations in force.

Immergas ducting systems



The Ø 60 rigid, Ø 50 and Ø 80 flexible and Ø 80 rigid “Green Range” ducting systems must only be used for domestic use and with Immergas condensing boilers.

In any case, ducting operations must respect the provisions contained in the standard and in current technical regulations; in particular, the declaration of conformity must be compiled at the end of work and on commissioning of the ducted system.

The instructions in the project or technical report must likewise be followed, in cases provided for by the standard and current technical regulations.

To guarantee reliability and operation over time of the ducting system, make sure:

- it is used in average atmospheric and environmental conditions, according to current regulations (absence of combustion products, dusts or gases that can alter the normal thermophysical or chemical conditions; existence of temperatures coming within the standard range of daily variation, etc.).
- Installation and maintenance must be performed according to the indications supplied by the manufacturer included with the “green range” ducting system chosen and in compliance with the regulations in force.
- The maximum length specified by the manufacturer must be respected; in this regard:
 - The max. possible length of the Ø 60 flexible ducting vertical section is equal to 22 m. This length is obtained considering the complete Ø 80 exhaust terminal, 1 m of Ø 80 pipe in exhaust, two 90° Ø 80 bends at boiler outlet.
 - The max. possible length of the Ø 80 flexible ducting vertical section is equal to 18 m. This length is obtained considering the Ø 80 complete exhaust terminal, 1 m of Ø 80 pipe in exhaust, two 90° Ø 80 bends at boiler outlet for connecting to the ducting system and two direction changes of the flexible hose inside the chimney/technical slot.
 - The max. possible length of the Ø 80 flexible ducting vertical section is equal to 6.7 m. This length is obtained considering the Ø 80 complete exhaust terminal, 1 m of Ø 80 pipe in exhaust, two 90° Ø 80 bends at boiler outlet for connecting to the ducting system and two direction changes of the flexible hose inside the chimney/technical slot.
- The maximum length that the Ø 50 flexible ducted tract can run is equal to 13 m straight. This length is obtained considering the complete Ø 80 exhaust terminal, 1 m of Ø 80 pipe in exhaust, two 90° Ø 80 bends at boiler outlet and the reduced Ø 80/50 T fitting.

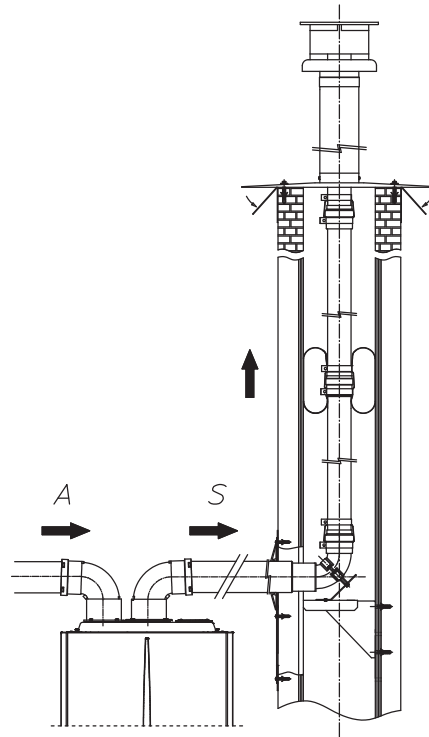

1.24 CONFIGURATION TYPE B, OPEN CHAMBER AND FAN ASSISTED FOR INDOORS

The appliance can be installed inside buildings in B₂₃ or B₅₃ mode; in this case, all technical rules and national and local regulations in force, must be complied with.

For installation, the cover kit must be used, referred to in (Par. 1.15).

1.25 FLUE EXHAUST TO FLUE/CHIMNEY.

Flue exhaust does not necessarily have to be connected to a branched type traditional flue for type B appliances with natural draught (CCR).

The flue exhaust, for boiler clots installed in C configuration, can be connected to a special LAS type multiple flue.

For B₂₃ configurations, exhaust is only allowed into individual chimney or directly into the external atmosphere via a relevant terminal, unless otherwise provided by local regulations.

The multiple flues and the combined flues must also only be connected to type C appliances of the same type (condensation), having nominal heat inputs that do not differ by more than 30% less with respect to the maximum that can be attached and powered by the same fuel. The thermo-fluid dynamic features (flue flow rate, % of carbon dioxide, % humidity etc.) of the appliances attached to the same multiple flues or combined flues, must not differ by more than 10% with respect to the average boiler attached.

Multiple and combined flues must be specially designed according to the calculation method and requirements of the standards (such as UNI 13384), by professionally qualified technical staff.

Chimney or flue sections for connection of the flue exhaust pipe must comply with requisites of technical standards in force.

It is possible to replace a type C conventional device with one provided with condensation only, if the derogation conditions established by the regulations in force have been verified.

1.26 FLUES, CHIMNEYS AND CHIMNEY CAPS.

The flues, chimneys and chimney caps for the evacuation of combustion products must be in compliance with applicable standards.

Chimneys and roof-installed exhaust terminals must comply with the outlet height and with the distance from technical volumes set forth by the technical standards in force.

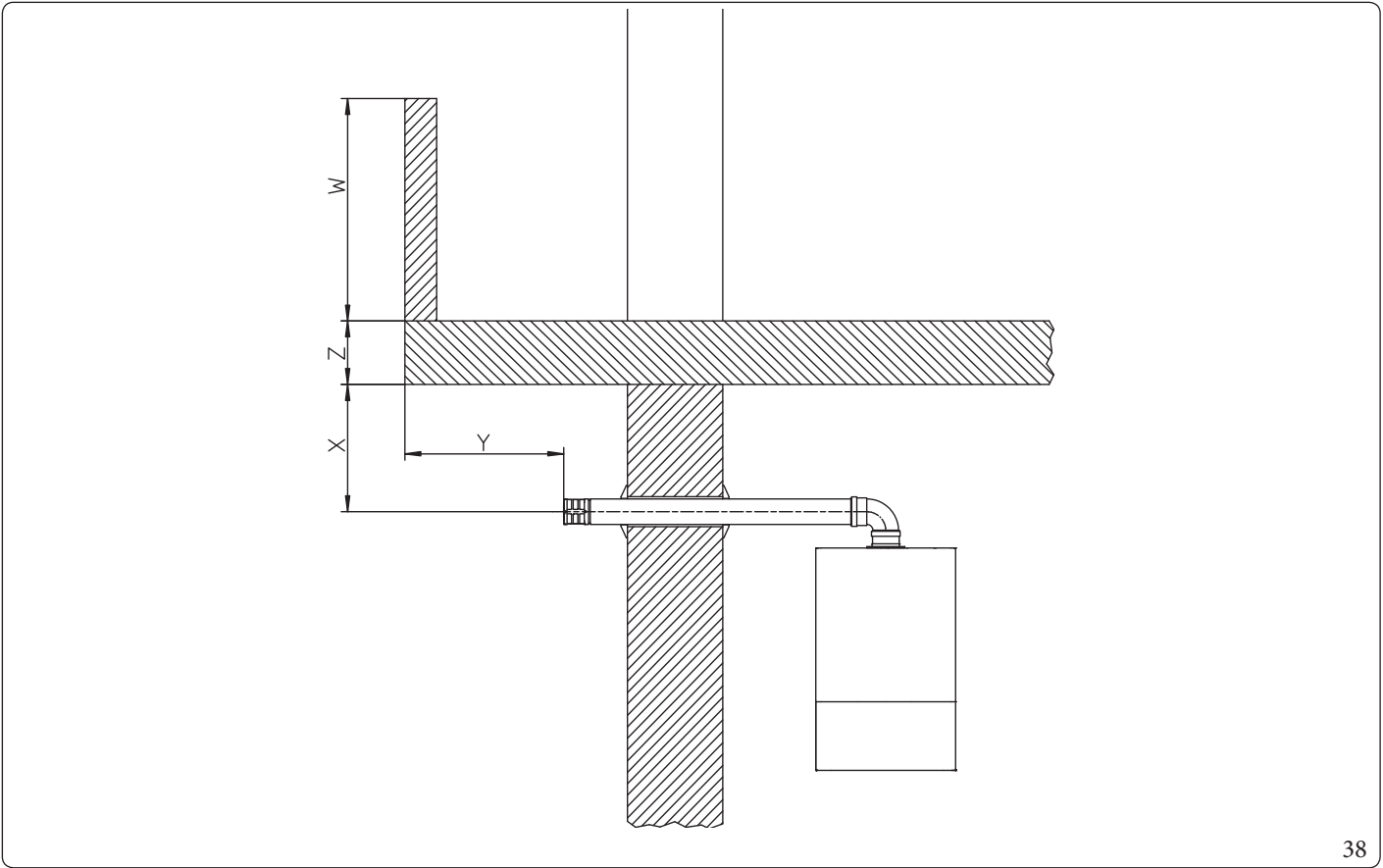

38

Positioning the wall flue exhaust terminals.

The wall flue exhaust terminals must:

- be installed on external perimeter walls of the building (Fig. 38);
- be positioned according to the minimum distances specified in current technical standards.

Combustion products exhaust of natural draught or fan assisted appliances in open-top closed environments.

In spaces closed on all sides with open tops (ventilation pits, courtyards etc.), direct combustion product exhaust is allowed for natural draught or fan assisted gas appliances with a heat input range from 4 to 35 kW, provided the conditions as per the current technical standards are respected.

1.27 WATER TREATMENT PLANT FILLING

As already mentioned in the previous paragraphs, a treatment of the thermal and domestic system water is required, in compliance with the local standards in force.

The parameters that influence the duration and proper operation of the heat exchanger are the water's PH, total hardness, conductivity, and oxygen, together with the system's processing residues (any welding residues), any oil present and corrosion products that can, in turn, cause damage to the heat exchanger.

In order to prevent this from happening, you are recommended to:

- clean the system with clean water to eliminate solid residues before installation on new and old systems;
- clean the system with a chemical treatment:
 - clean the new system with a suitable cleaning device (for example Sentinel X300, Fernox Cleaner F3 or Jenaqua 300) combined with thorough washing;
 - clean the old system with a suitable cleaning device (for example Sentinel X400 or X800, Fernox Cleaner F3 or Jenaqua 400) combined with thorough washing;
- Check the maximum total hardness and quantity of filling water referring to the graphics (Fig. 39); if the contents and hardness of the water are below the indicated curve, no specific treatment is required; otherwise, to limit the content of calcium carbonate, you must provide for water-filling treatment.
- If it is necessary to provide for water treatment, it should be done through complete desalination of the filling water. As opposed to the complete softening process, desalinating the water completely not only removes hardening agents (Ca, Mg), but also eliminates all other minerals to reduce water-filling conductivity up to 10 microsiemens/cm. Given its low conductivity, desalinated water does not only prevent the formation of lime scale, but also serves as protection against corrosion.
- Insert a suitable inhibitor / passivator (for example Sentinel X100, Fernox Protector F1, or Jenaqua 100); if required, also insert appropriate antifreeze (such as for example Sentinel X500, Fernox Alphi 11 or Jenaqua 500).
- Check electrical conduction of the water, which should be higher than 2000 $\mu\text{s}/\text{cm}$ in the case of treated water and lower than 600 $\mu\text{s}/\text{cm}$ in the case of non-treated water.
- To prevent corrosion, the water system's PH should be between 7.5 and 9.5.
- Check the maximum content of chlorides, which should be less than 250 mg/l.



For quantities and methods of use of water-treatment products, refer to the instructions provided by their manufacturer.

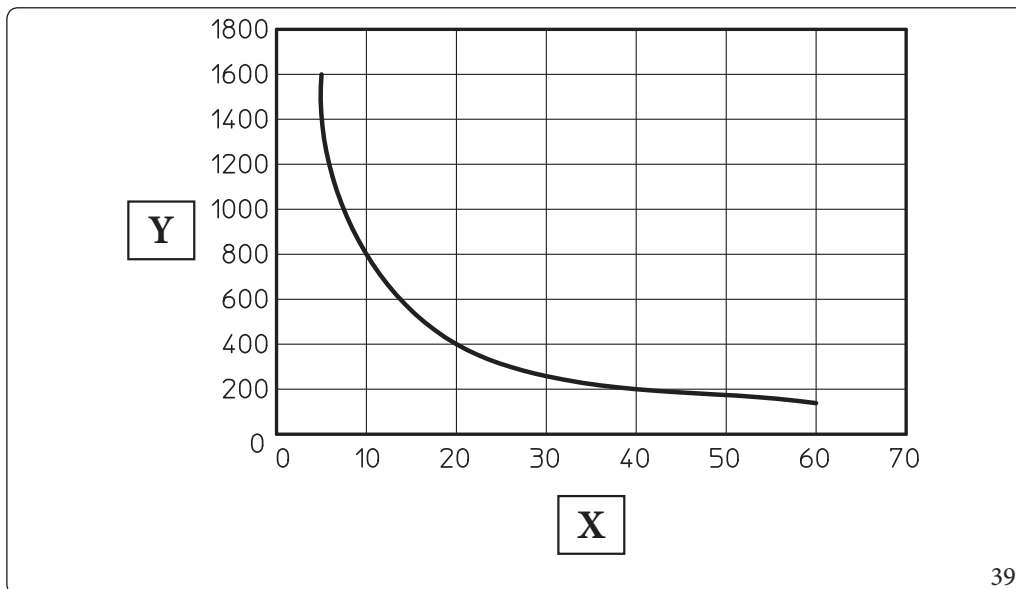

Key (Fig. 39):

- X - Total water hardness °F
- Y - Litres of system water



The graph refers to the entire life cycle of the system. Therefore, also consider scheduled and unscheduled maintenance, which involves emptying and filling the said system.

1.28 SYSTEM FILLING

Once the boiler is connected, proceed with system filling via the filling cock (Part. 1 Fig. 34).

Filling is performed at low speed to ensure release of air bubbles in the water via the boiler and central heating system vents.

The boiler has a built-in automatic vent valve on the pump.

Check if the cap is loose.

Then open the radiator vent valves.

Close radiator vent valves when only water escapes from them.

Close the filling valve when the boiler pressure gauge indicates approx. 1.2 bar.



During these operations activate the automatic venting functions present in the boiler.

1.29 FILLING THE CONDENSATE DRAIN TRAP



On first lighting of the boiler, flue gas may come out the condensate drain; after a few minutes' operation check that this no longer occurs. If this is the case, the drain trap is correctly filled with condensate up to a height that does not allow the flue gas to pass.

1.30 GASSYSTEM START-UP.

To start up the system, refer to the technical standards in force.

This divides the systems and, therefore, the commissioning operations, into three categories: new systems, modified systems, reactivated systems.

In particular, for new gas systems:

- open windows and doors;
- avoid presence of sparks or naked flames;
- bleed all air from pipelines;
- ensure the internal system is properly sealed according to the specifications set forth by technical regulations in force.

1.31 BOILER START-UP (IGNITION)



The display leaves the factory set in Italian. To change the display language, see Par. 2.5 in the "USER" chapter, under "Changing the display language".

To commission the boiler (the operations listed below must only be performed by qualified personnel and in the presence of staff only):

1. check that the internal system is properly sealed according to the specifications set forth by regulations in force;
2. Ensure that the type of gas used corresponds to the boiler settings (the type of gas appears on the display on first electrical power supply);
3. check that there is no air in the gas pipe;
4. check connection to a 230V-50Hz power mains, correct L-N polarity and the earthing connection;
5. check that the intake/exhaust terminals are not obstructed and that they are installed properly;
6. **Check that the drain trap is full and that it prevents any passage of flue gas into the room;**
7. check that there are no external factors that may cause the formation of fuel pockets;
8. Carry out the flue test (Par. 3.14);
9. **Activate the Quick calibration function (if in the previous check it was necessary to change the flue parameters):** (Par. 3.13);
10. switch the boiler on and ensure correct ignition;
11. Make sure that the gas flow rate and relevant pressure values comply with those given in the manual (Par. 4.1);
12. ensure that the safety device intervenes in the event of gas supply failure and check the relative intervention time;
13. check the intervention of the main switch located upstream from the boiler and in the boiler.



Even if just one single safety check provides a negative result, do not commission the system.

Data nameplate positioning

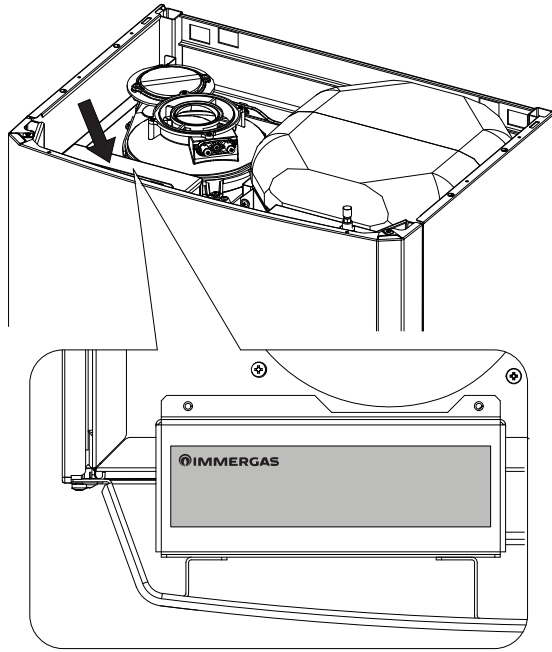

40

1.32 CIRCULATION PUMP

During central heating mode, the Auto and Fixed operating modes are available.

- **T delta = 0**: automatic pump speed and proportional head: the pump speed varies according to the power supplied by the burner, the greater the power the greater the speed. Moreover, within the parameter, it is possible to adjust the pump operating range by setting the “Maximum speed” parameter (adjustable from 6 to 9) and the “Minimum speed” parameter (adjustable from 6 to max set speed).
- **Delta t = 5 ÷ 25 K**: the pump speed varies to maintain the ΔT constant between the system flow and return according to set value K ($\Delta T = 15$ Default).
- **Fixed (6 - 9)**: by setting the parameters “Maximum speed” and “Minimum speed” at the same value, the pump operates at constant speed.



For the boiler to work properly, it is not allowed to drop below the minimum speed value = 6.



In domestic hot water mode, the circulator pump always runs at full speed.

Pump LED.

The LED flashes green when the pump is powered and the pwm control signal is connected.



The LED lights up steady green when the pump is powered and the signal cable disconnected. In these conditions the pump works at maximum and without control.

If the pump detects an alarm, the LED switches from green to red; this can mean one of the following failures:

- low supply voltage;
- rotor seized;
- electrical error.

For a detailed description of the meaning of the red LED, refer to Paragraph 3.7.



The LED, in addition to being green or red, can also remain off.

It is normal for the LED to be off when the pump is not powered, whereas with the pump powered, the LED must be lit: if switched off, it means there is a fault.

Pump release.

If after a long period of inactivity, the circulator is blocked, adjust the screw in the centre of the head in order to manually release the motor shaft.

Take great care during this operation to avoid damage to the motor.

Bypass Adjustment (Parag. 1.34).

The boiler leaves the factory with the bypass open.

If necessary, the by-pass can be regulated to system requirements from minimum (by-pass closed) to maximum (by-pass open).

Adjust using a flat head screwdriver, turn clockwise and open the by-pass, anticlockwise it is closed.



The bypass ensures minimum circulation of the water in the boiler and correct operation of the appliance in case of systems with shut-off components or external hydraulic adjustments.

Head available to the Victrix Zeus Superior 25 system

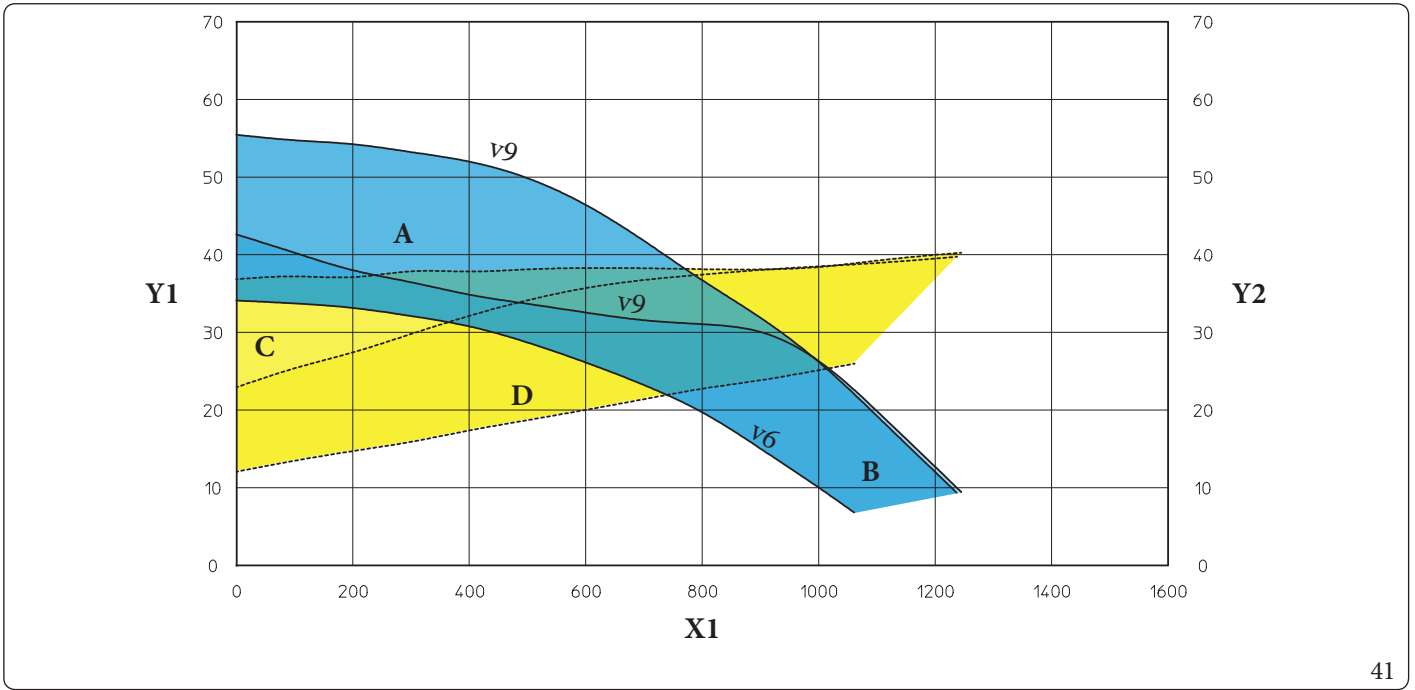

41

Head available to the Victrix Zeus Superior 30 - 35 system

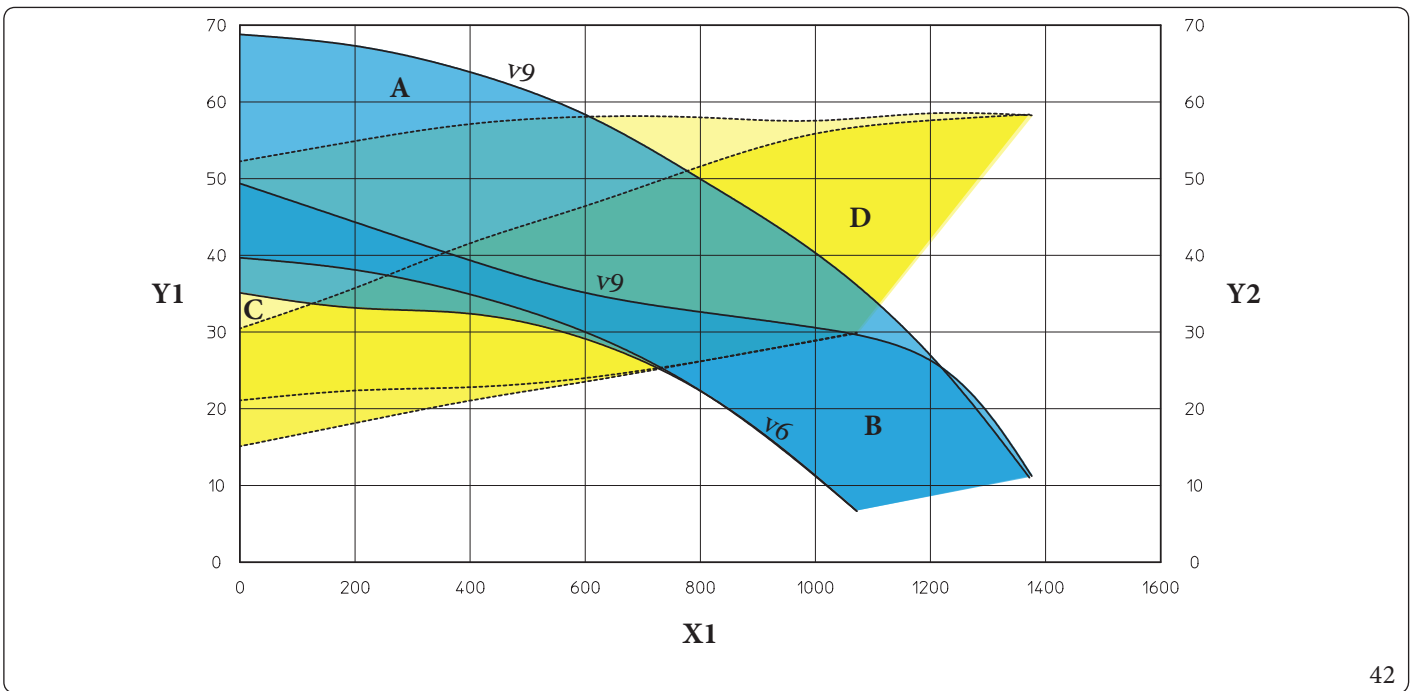

42

Key (Fig. 41, 42):

- A+B = Head available with bypass closed
- B = Head available with bypass open
- C+D = Power absorbed by the pump with bypass closed (dotted area)
- D = Power absorbed by the pump with by-pass open (dotted area)

Key (Fig. 41, 42):

- X1 = Flowrate (l/h)
- Y1 = Head (kPa)
- Y2 = Power absorbed by pump (W)
- v6 = Speed 6
- v9 = Speed 9

1.33 KITS AVAILABLE ON REQUEST

- System cut-off valve kits with or without inspectionable filter (on request). The boiler is designed for installation of system interception cocks to be placed on flow and return pipes of the connection assembly. This kit is very useful for maintenance because it allows to empty just the boiler without having to empty the entire system. Moreover, the version with filter preserves the functioning characteristics of the boiler thanks to its inspectionable filter.
- Polyphosphate dispenser kit (on request). The polyphosphate dispenser reduces the formation of lime-scale and preserves the original heat exchange and domestic hot water production conditions. The boiler is prepared for application of the polyphosphate dispenser kit.



This is a type of chemical conditioning treatment for domestic hot water, if provided for by current regulations.

- Cycloidal filter kit (on request). The magnetic cycloidal filter is able to detect the ferrous residues present in the system's water. Thanks to the two cocks in the kit, it facilitates maintenance by cleaning the filter without having to empty the circuit.



The above-mentioned kits are supplied complete with instructions for assembly and use.

Wireless room probes kit (on request). The wireless room probes kit is the optimal solution for controlling the room temperature. Through it, in fact, it will be possible to set on the individual zones the room temperature with which to control the central heating / C.H. ignition; the central heating / C.H. flow set at which the boiler will operate will be regulated to the ideal temperature for maintaining room comfort, with maximum energy saving.

1.34 MAIN COMPONENTS

INSTALLER

USER

MAINTENANCE TECHNICIAN

TECHNICAL DATA

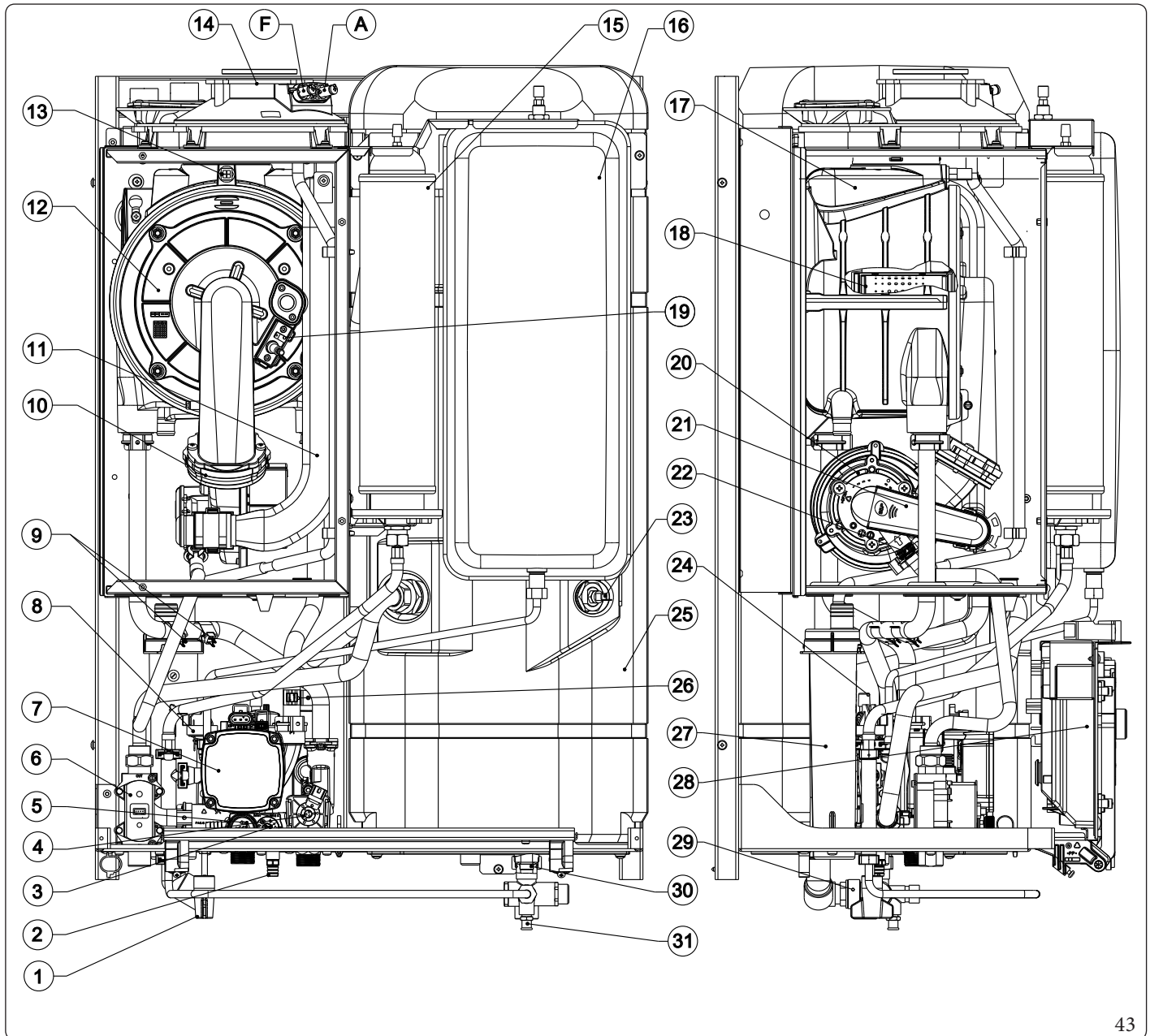

Key (Fig. 43):

- | | | | |
|----|---|----|----------------------------------|
| 1 | - Filling cock / tap | 16 | - System expansion vessel |
| 2 | - Draining cock / tap | 17 | - Heat exchanger |
| 3 | - By-pass | 18 | - Burner |
| 4 | - 3-way valve (motorised) | 19 | - Ignition / detection electrode |
| 5 | - 3 bar safety valve | 20 | - Fan |
| 6 | - Gas valve | 21 | - Gas mixer |
| 7 | - Boiler circulating pump | 22 | - Gas diaphragm |
| 8 | - Absolute pressure switch | 23 | - D.H.W. probe |
| 9 | - Double flow probe | 24 | - Air vent valve |
| 10 | - Non-return valve on flue gas | 25 | - Stainless steel storage tank |
| 11 | - Air intake pipe | 26 | - Return probe |
| 12 | - Gas manifold | 27 | - Condensate drain trap |
| 13 | - Double flue probe sensor | 28 | - Control panel |
| 14 | - Flue hood with sample points (air A) - (flue gas F) | 29 | - 8 bar safety valve |
| 15 | - Domestic hot water expansion vessel | 30 | - Flow limiter |
| | | 31 | - Storage tank draining valve |

43

2 INSTRUCTIONS FOR USE AND MAINTENANCE

2.1 GENERAL RECOMMENDATIONS



Never expose the wall-mounted boiler to direct vapours from a cooking surface.



The device can be used by children at least 8 years old as well as by persons with reduced physical, sensory or mental capabilities, or lack of experience or required knowledge, provided that they are under surveillance, or after they have been instructed relating to the safe use and have understood the potential dangers.

Children must not play with the appliance.

Cleaning and maintenance destined to be performed by the user can not be carried out by unsupervised children.



For safety purposes, check that the air intake/flue exhaust terminals (if fitted) are not blocked.



If temporary shutdown of the boiler is required, proceed as follows:

- a) drain the heating system if antifreeze is not used;
- b) shut-off all electrical, water and gas supplies.



In the case of work or maintenance to structures located in the vicinity of ducting or devices for flue extraction and relative accessories, switch off the appliance and on completion of operations ensure that a qualified technician checks efficiency of the ducting or other devices.



Never clean the appliance or connected parts with easily flammable substances.



Do not open or tamper with the appliance.



Never leave containers or flammable substances in the same environment as the appliance.



Do not take apart or tamper with the intake and exhaust pipes.



Only use the user interface devices listed in this section of the booklet.



Do not climb on the appliance, do not use the appliance as a support base.



The use of components involving use of electrical power requires some fundamental rules to be observed such as:

- do not touch the appliance with wet or moist parts of the body; do not touch when barefoot;
- never pull electrical cables or leave the appliance exposed to atmospheric agents (rain, sunlight, etc.);
- the appliance power cable must not be replaced by the user;
- in the event of damage to the cable, switch off the appliance and contact exclusively qualified staff for replacement;
- if the appliance is not to be used for a certain period, disconnect the main boiler external switch.



Water at a temperature of more than 50 °C can cause serious burns. Always check the water temperature before any use.



The temperatures indicated by the display have a tolerance of +/- 3°C due to environmental conditions that cannot be blamed on the boiler.



After brief periods of inactivity, visually check that the siphon is properly filled with condensate and top it up if necessary.



If you smell gas in the building:

- close the gas meter interception device or the main interception device;
- if possible, close the gas interception cock on the product;
- if possible, open doors and windows wide and create an air current;
- do not use open flames (e.g. lighters, matches);
- do not smoke;
- do not use electrical switches, plugs, door bells, telephones or intercom devices in the building;
- call an authorised company (e.g. Authorised Technical Assistance Centre).



if you smell burning or see smoke coming out of the appliance, switch it off, disconnect power, close the main gas cock, open the windows and call an authorised company (e.g. Authorised Technical Assistance Centre).



At the end of its service life, the appliance must not be disposed of like normal household waste nor abandoned in the environment, but must be removed by a professionally authorised company as required by current legislation. Contact the manufacturer for disposal instructions.

2.2 CLEANING AND MAINTENANCE



To preserve the boiler's integrity and keep the safety features, performance and reliability, which distinguish it, unchanged over time, you must execute maintenance operations on a yearly basis in compliance with what is stated in the relative point at "annual check and maintenance of the appliance" in compliance with the prevailing national, regional or local provisions.

2.3 CONTROL PANEL

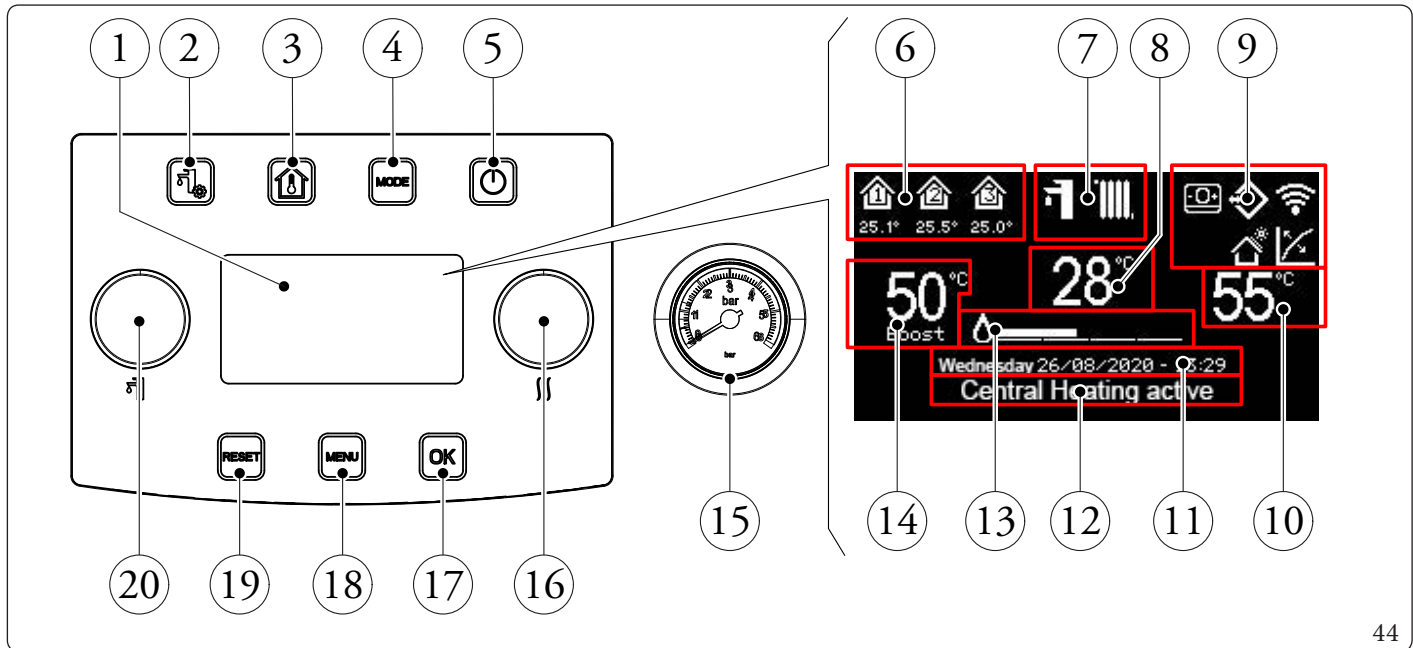

Key (Fig. 44):

- | | | | |
|----|---|----|---|
| 1 | - Display. | 11 | - Current date and time display. |
| 2 | - Domestic hot water button. | 12 | - System state. |
| 3 | - Zone button. | 13 | - Power scale. |
| 4 | - Functioning mode button. | 14 | - DHW (Domestic hot water) set display. |
| 5 | - ON/OFF Button. | 15 | - Pressure gauge. |
| 6 | - Zones area (number and information of zone in use). | 16 | - "Set central heating/ C.H." knob. |
| 7 | - Operating mode. | 17 | - Selection confirmation/ok button. |
| 8 | - Anomaly code/flow temperature display. | 18 | - Menu button. |
| 9 | - System general icon display. | 19 | - Anomalies/esc. reset button. |
| 10 | - Central heating/ C.H. set display. | 20 | - "Set DHW (Domestic hot water)" Knob. |

2.4 BOILER USE



Before ignition make sure the heating system is filled with water and that the manometer (7) indicates a pressure of $1 \div 1.2$ bar.

The following are displayed upon ignition:

- Type of panel;
- Panel firmware version;
- Board firmware version.
- Type of selected gas

Once the device has been powered, it goes into the status prior to switch-off. Press the "MODE" button to cyclically select the desired operating mode amongst those available.

The operating mode in use is displayed by the relative icon at the top of the display (Fig. 45) and it is unique for all zones. By pressing any button, the pushbutton panel lights up for a few seconds; in this way it is activated and ready to receive the subsequent commands. Depending on the system's configuration, the main screen displays various information regarding the system itself, amongst which:

Symbol	Description and operation
	Zone identification icon. This icon reverses its colour during the central heating / C.H. demand. The values below the zone icon, respectively indicate the temperature or any errors in such zone. The temperature and any errors are displayed if the wireless room probe is configured; if CAR ^{V2} is connected, the zone 1 icon will indicate the room temperature read by the CAR ^{V2} ; if no probe is connected or CAR ^{V2} remains active, only the “home” (zone) icon remains active without any other info below.
	Remote management system connection icon.
	CAR ^{V2} presence icon.
	External probe connection.
	Connection to wireless room probes (optional).
	Burner on with flame present (the bar at the side indicates a progressive increase of the power supplied by the burner).

Operating mode	Description	DHW	Central heating	Protection function (Antifreeze...)
OFF	Off	Disabled	Disabled	Disabled
	Summer	Enabled	Disabled	Activated
	Winter	Enabled	Enabled	Activated
	Stand-by	Disabled	Disabled	Activated

2.5 OPERATING MODE

The boiler can work in the following modes:

- OFF;
- STAND-BY ();
- SUMMER ();
- WINTER (.

If the boiler is at “OFF”, press the button “” to activate it. If this is not the case, go to the next point. Then press the “MODE” button in sequence to set the system to stand-by , summer or winter position.

- "OFF" mode



In “Stand-by” and “Off” mode, the boiler is still powered.

By pressing this button, the display will show "OFF" and the system will be off. In this mode, the safety functions are not guaranteed and the remote devices are disconnected.

- “Stand-by” Mode

Press the “MODE” button in succession until the symbol appears

In this mode, the system is able to ensure protection functions only, such as: boiler antifreeze function, antiblock function and any anomaly signals (Fig. 45).

- Summer

Press the “MODE” button in succession until the symbol appears.

In this mode the boiler allows the production of domestic hot water and ensures protection (Fig. 45).

- Winter

Press the “MODE” button in succession until the symbol appears.

In this mode the system allows the production of domestic hot water and room central heating / C.H. and ensures protection (Fig. 45).

Display operation

Below is a description of how to use the control panel, including:

- Enter the menus;
- Moving in the menus;
- Set a menu item;
- Confirming a change;
- Exit without saving.

• Enter the menus

The control panel menus can be accessed by pressing the buttons (Fig. 44):

- “DHW (Domestic hot water)” to enter the DHW (Domestic hot water) menu;
- “Zones” to enter the Zone menu;
- “Menu” to enter the general settings menu.

• Moving in the menus

Simply rotate the “Set DHW (Domestic hot water)” knob to scroll the menu items.

The indication “[...]” next to the menu item indicates the availability of a submenu.

Press the “OK” button to access this submenu.

Pressing the “RESET” button goes back to the previous menu page.

• Set menu item

Go to the menu item to be set following the instructions given previously.

Once the menu item to be set is reached, press “OK” or rotate the “Set Central heating / C.H.” knob to highlight the value to be changed.

Change the value by turning the “Set central heating / C.H.” knob.

• Confirming a change

At the end of the modification, press “OK” to confirm the change and go back to the previously selected menu item.

• Exit without saving

If at the end of the modification you press “RESET”, you will return to the previously selected menu item without confirming the modification.

Changing the display language

The display leaves the factory set in Italian, proceed as follows to change the display language:

- Enter **Menu/Impostazioni generali/Lingua**.
- Select the desired language from those available and press OK.

Clock and programs

From this menu, it is possible to set the system's date and time as well as the time slots for operation in Comfort and Economy mode.

• Date and time.

The date and time can be set by modifying the parameters in the menu

Time and program/Settings date and time.

Setting date and time	
HOUR	↕ 22:22
DAY	5
MONTH	1
YEAR	2020

46

• Automatic summer time

Time and program/Auto switch to DST

It is possible to enable or disable the automatic summer time.

- **Calendars**

It is possible to set 4 calendars with 4 time operating slots in system comfort mode. The system will operate in economy mode during out-of-range time of these 4 time slots.

After setting these 4 calendars it is possible to associate them to the various days of the week in the zone programs, DHW (Domestic hot water) according to one's needs.

Set the time slots by modifying the menu

Time and program/Calendars

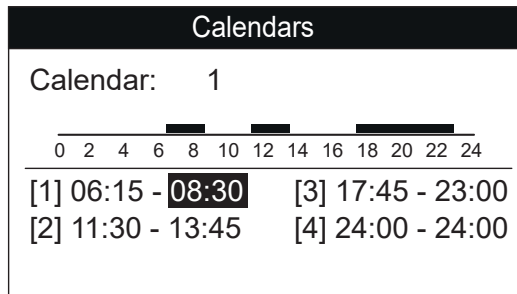

47

- **Program for Zone 1, Zone 2 (if present), Zone 3 (if present), DHW (Domestic hot water) and Central heating/ C.H.**

In these menus DHW (Domestic hot water) and Central heating/ C.H. time ranges (calendars from 1 to 4) are assigned to Zone 1, Zone 2 (if present), Zone 3 (if present).

You can assign the calendar to a single day or to a group of days (single day, Monday - Friday, Saturday - Sunday, Monday - Saturday, Monday - Sunday).

Therefore each day may be personalised with 4 different operating programs.

For convenient selection, the bottom part displays the graphics of the relevant calendar being selected (Fig. 48).

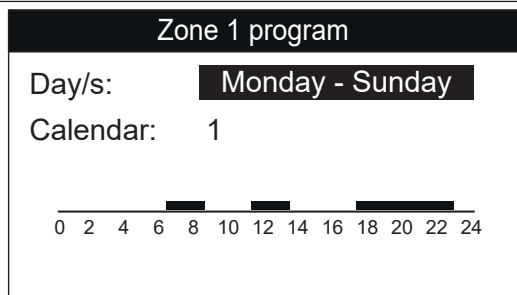

48



On the menu

Zones/Information

it is possible to identify the status of the various controls managing the central heating / C.H..

- **Holiday program.**

Time and program/Holiday program

If required, it is possible to pause system operation for an established period.



Both the DHW (Domestic hot water) control and central heating / C.H. are stopped.

Set the number of system operation suspension days.



The day on which the holiday program is set is counted as the first day of system suspension.

The antifreeze function is still ensured during the holiday period.



In case of blackout, the holiday program is cancelled.

List of functions

The following functions can be set on the boiler:

- DHW (Domestic hot water);
- Central heating / C.H.;

DHW

"Domestic hot water active" appears on the display during the activation.

It is possible to set the domestic hot water temperature adjustment in two ways: MANUAL or AUTOMATIC.

The selection is made by entering the DHW (Domestic hot water) menu ("DHW (Domestic hot water)" button) and setting the "Set management" parameter.

Manual adjustment (Man)

The temperature adjustment of the DHW (Domestic hot water) in MAN mode is made using the "Set DHW (Domestic hot water)" knob (Fig. 44) or by modifying the "Manual set" value within the "DHW settings" menu.

Confirmation can take place in two ways: by pressing the OK button or by waiting two minutes after changing the value.

Automatic adjustment (Auto)

The AUTOMATIC domestic hot water temperature adjustment involves setting the "Set comfort" and "Set economy" parameters in the "DHW settings" menu and choosing the calendar inside the menu

Time and program/DHW Program

In the selected time slots, the DHW (Domestic hot water) set will be automatically set to the "Set comfort" value; outside these, the set DHW (Domestic hot water) will be set to "Set economy" value.

It is possible to temporarily modify the DHW (Domestic hot water) set by setting a manual value using the "Set DHW (Domestic hot water)" knob (Fig. 44).

This setting will be lost when the time slot is next changed.

If the DHW (Domestic hot water) temperature is changed in "Auto" automatic operation, the "Set DHW (Domestic hot water)" knob activates the timed manual operation. In this mode, the DHW (Domestic hot water) temperature is regulated to the value set until the next band change of the programmed DHW (Domestic hot water) program. The forced automatic function can be interrupted by simply pressing the "MODE" button.

Boost Function

It is also possible for Domestic hot water / D.H.W. to set the "Boost" function.

When the Boost is active, the word "Boost" appears in the display below the "Set DHW (Domestic hot water)" temperature (Fig. 44):

To set this function, press the "DHW (Domestic hot water)" button and select the "Boost function" which has three modes (ON - OFF - AUTO):

- **Boost ON** (Comfort): with Boost active, the boiler maintains the set domestic hot water temperature constant. This provides maximum comfort but with frequent burner ignitions.
- **Boost OFF** (Economy): the Boost is off and sufficient comfort is had with a few ignitions;
- **Auto**: Boost is managed simultaneously with the time slots set on the boiler DHW (Domestic hot water) program or the CAR V2 if present (active in comfort and deactivated in economy).

Central heating



To verify if the central heating / C.H. is actually in operation, look at the Zone area icon: if it is full it means that central heating / C.H. is active, otherwise, even when the room thermostat is open, it will be empty.

The central heating / C.H. adjustment can be set in three ways: MANUAL, AUTOMATIC, OFF.

The selection is made by entering the "Zone" menu .



In case of single-zone system, only Zone 1 will appear.

In case of multi-zone system, Zone 2 and/or Zone 3 will also appear.

After having selected the zone of interest, access the menu:

Settings/Function Mode

Use with Room thermostat TA (Optional)



If there is no Room thermostat, the jumper at the ends of terminals 40-41 must be maintained. In this conditions, a continuous request from the Room thermostat is simulated

Man functioning mode

With this setting, the central heating / C.H. (as maximum flow set system flow temperature) is manually enabled and will be valid until the subsequent and different setting.

With single-zone systems, the maximum flow set is also available on the central heating / C.H. set knob; on multi-zone systems it can be set on the menu Zones\Definition\Regulation.

When the room temperature (if TA present) exceeds that set on the TA, the central heating / C.H. turns off.

Auto functioning mode

By associating a calendar with the relevant zone program, it is possible to determine the time slots for activating the room central heating / C.H. at a system temperature as set on "Set flow".

When the room temperature detected by any Room thermostat is lower than required, the central heating / C.H. is activated (only if requested by the calendar program).

When the room temperature detected by any Room thermostat is higher than required, the room central heating / C.H. is deactivated.

Functioning mode Off

Central heating / C.H. always off.

Anti-Legionella function

If the anti-legionella function is activated (disabled as a standard), the temperature inside the storage tank is brought to 65°C for 30 minutes.



Water at temperatures above 50°C can cause severe burns. When the anti-legionella function is activated, always check the water temperature before any use.

Use with wireless room probes (Optional)



Using Central heating / C.H. through the wireless room probes is the optimal solution for controlling the room temperature.

With room probes configured and enabled, it will be possible to set on the individual zones the room temperature with which to control the central heating / C.H. ignition; the central heating / C.H. flow set at which the boiler will operate will be regulated to the ideal temperature for maintaining room comfort, with maximum energy saving.

Man functioning mode

With this setting, the central heating / C.H. is manually disabled and the value set on "Zones\Settings\Set MAN" (room temperature demand) will be valid until the subsequent and different setting.

When the room temperature exceeds the set room set, the central heating / C.H. turns off.

Auto functioning mode

There are two reference setpoints:

Zones\Settings\Set AUTO Comfort

Zones\Settings\Set AUTO Reduced

By associating a calendar with the relevant zone program, it is possible to determine the time slots when to activate the room temperature control set as Comfort (Set Auto Comfort); the reduced room temperature control (Set Auto reduced) will be active in the remaining time intervals. The flow set will be automatically calculated according to the room temperature (If the default setting "Room sensor modul" = YES is maintained).

When the room temperature detected by any Room probe is lower than required, the central heating / C.H. is activated.

When the room temperature detected by any Room probe is higher than required, the room central heating / C.H. is deactivated.

Functioning mode Off

Central heating / C.H. always off.



The presence of the jumper on the TA contact is required when the central heating / C.H. demand needs to be checked using only the wireless room probes.

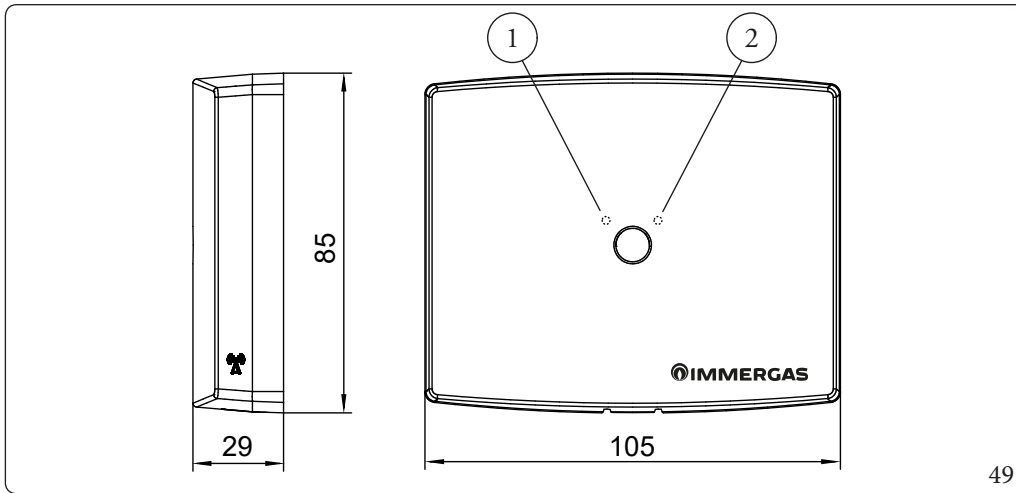

Key (Fig. 49):
 1 - Left LED
 2 - Right LED

Wireless probe LED behaviour

On the wireless probe there are two LEDs next to the button. The possible signals on these LEDs are the following:

Status	Situation	Left LED	Right LED
Normal functioning	Normal functioning	1 Flash every 60 seconds	
	No association	1 Flash every 4 seconds	
	RF transmission in progress		1 Flash

Boiler operation with wireless room probes

The wireless room probe (with concentrator) allows the measurement of the room temperature and sending of this value to the boiler control panel where possible, via the display board, set a weekly program for the room temperature control. There is no manual command or adjustment of the room control on the probe.

i The key on the probe and concentrator has no function for the end user. It is recommended not act on this button, on any of the devices.

Room antifreeze function with wireless room probes

The room antifreeze protection is activated when the zone operating mode is set to Off and the boiler is in Winter mode. The antifreeze function can be deactivated through the menu with Service access.

With zone operation = Off, in case of room sensor fault, the boiler will NEVER receive any room central heating / C.H. request (not even in case of antifreeze). Only the boiler antifreeze function will remain active.

If you want to ensure the room is protected from freezing (also in the presence of any faults on the sensors), it is possible to select the zone operating mode = Manual and set the minimum room set; in these conditions, the probe flow produces a central heating / C.H. request (permanent 24h) with minimum flow set.

Boiler flow temperature with wireless room probe

By activating the "Room probe modul." function, the boiler will automatically manage the flow temperature making it correlated to the actual room need. The boiler flow temperature will vary between the maximum and minimum values set on the zone parameters and will proportionally decrease when the desired room temperature is reached.

By deactivating the "Room probe modul." function, the boiler flow temperature will remain fixed at the maximum value set on the zone parameters for the entire central heating / C.H. request time; if multi-zones present with several probes, the boiler will provide the highest flow temperature among the requests from the various zones. A different maximum and minimum flow temperature value can be defined for each individual zone.

Combined operation of wireless room probe with external probe

If the "Outdoor sensor modul." and "Room probe modul." functions are kept active, the combined wireless room probe and external probe operation makes it possible to add together the boiler flow temperature calculation actions.

Based on the outdoor temperature, the flow temperature calculation function will determine the maximum flow temperature for the zone (correlated to the temperature outside at that moment). The room probe can further decrease the value based on the rising of the room temperature.

Boiler operation in case of wireless room probe fault

Radio communication lost between room probe and concentrator

Failed data reception by the wireless probe causes the relative error to appear on the display.

Typically the error is reported after 4 minutes; the last reading on the room probe is kept active with consequent central heating mode function referring to this reading.

After 10 minutes of no communication, the boiler determines that the probe is “out of order”; two dashes appear on the display instead of Room T keeping the error signal under the icon of the zone house active.

Operation with room probe “out of order” causes a central heating / C.H. request from the boiler with minimum zone flow set in any selected program condition (permanent 24h).

The only central heating / C.H. off condition is the selection of the OFF status on the zone menu or the Summer selection.

Fault on room sensor NTC

Already at the first communication of an out of range room value (MAX after 4 minutes), the probe assumes the “out of order” condition; then proceed with the operation described above (permanent central heating / C.H. request at minimum set in any operating condition other than the OFF state).

Fault on the concentrator (receiver connected to boiler)

In case of concentrator offline error, the boiler behaves as in probe “out of order” condition.

Adjustments available on display with the presence of wireless room probes

Following correct association, the zones menu is available to manage the central heating / C.H. operation with wireless room probe; if only one zone is associated, the zone 1 menu will be available otherwise, if the appropriate zone actuator boards are connected and set, zone 2 and zone 3 will also be available.

With only 1 zone, the boiler control panel central heating / C.H. adjustment knob will provide the adjustment of the maximum central heating / C.H. temperature (or offset if the external probe is present). The room temperature settings and adjustments are available by accessing the zone menu.

With multiple zones connected, acting on the boiler control panel central heating / C.H. adjustment knob will give direct access to the zone menu where it will be possible to choose the zone of interest and select the size to be varied (both flow temperature and room temperature).

Adjustment of the central heating system flow temperature



The flow temperature will only be activated when the central heating / C.H. request is present.

The system will ask the boiler for a radiator flow temperature capable of satisfying the maximum request; as the room warms up, the boiler will also adapt by lowering the radiator flow temperature (thus reducing consumption).

Modulation on the flow only activates if wireless room probes are present. Without wireless probes, the flow will remain fixed (or correlated with the external probe).

By acting directly on the “Set central heating / C.H.” knob it is possible to set value “A” (Fig. 9) setting the flow temperature to the system with active request.

No external probe

Without external probe, following central heating / C.H. adjustment using the knob, the display shows the actual temperature set for central heating / C.H.; if the value is not maintained, it is because the functioning mode of the zone is set on A-ECO or OFF (20°C).

External probe present (optional)

The “Set Central heating / C.H.” knob will set the “E” OFF-set (Fig. 9).

With the external probe present, the boiler calculates the central heating system temperature according to the outdoor temperature; in these conditions the user is still allowed to set a correction (offset) on the room temperature using the “Set central heating / C.H.” knob, in relation to the outdoor temperature detected by the probe.

Operation with Comando Amico Remoto remote control^{V2} (CAR^{V2}) (optional)



In case of single-zone system, this will be managed via CAR^{V2}.

In case of multi-zone system, the CAR^{V2} will only manage zone 1: zone 2 and/or zone 3 will be managed by the TA and/or room probes.

When the Car V2 is connected, the display will no longer show any setting concerning zone 1, while maintaining the main information. The  symbol will appear on the display. The boiler regulation parameters can be set via the CAR^{V2} control panel, all the buttons remain active on the boiler control panel (except the MODE button) and the display where the functioning state is shown.



If the boiler is put into “off” mode, the “ERR>CM” connection error symbol will appear on the CAR^{V2}. The CAR^{V2} is however powered constantly so as not to lose memorised programs.



The presence of the jumper on the TA contact is required when the central heating / C.H. demand needs to be checked using only CARv2.

Operation with external probe

It is possible to use the thermoregulation functions associated to an external probe.

The boiler is designed for use with an optional external probe.

With the external probe connected, the flow setpoint for room central heating / C.H. is managed by the system depending on the external temperature measured (Par. 1.10).

It is possible to enable thermal adjustment for each individual zone. The symbol is present if the probe is connected and working.



If room probes are present, "Room temperature" appears displaying the reading of the zone room temperature.

If room probes are present, "Room Set" appears, showing the room set in progress.

Zone menu description/Information

• Operation status

- OFF = off;
- A-ECO = means that the zone is in the time slot where the central heating / C.H. has been programmed to be deactivated;
- A-COMF = means that the zone is in the time slot where the central heating / C.H. has been programmed to be activated and running if the room thermostat is closed;
- MAN = central heating / C.H. is always active and the relative time program is not considered.

• Room thermostat status

- if open, there is no central heating / C.H. request in progress (until it is closed);
- if closed, it will go in combination with the boiler programming.

• Central heating / C.H. set

- info on the actual active set in real time (depends on the central heating / C.H. programming or any external probe).

2.6 PARAMETERS AND INFORMATION MENU

Navigation diagram within the boiler display

There are 3 Settings menus (Fig. 44):

DHW (Domestic hot water): accessible by pressing the domestic hot water button (2);

Zones: accessible by pressing the zone button (3);

General settings menu: accessible by pressing the menu button (18).



Some menu settings appear only when the options are actually connected and working.

“DHW (Domestic hot water)” Menu.

Press the “DHW (Domestic hot water)” button to access a list of variables that enable you to customise use of the DHW (Domestic hot water).

Hereunder is a list of available menus:

DHW settings					
Menu item	Description	Range	Default	Customised value	
DHW control	Boiler = DHW (Domestic hot water) control managed from boiler panel				
	Remote = DHW (Domestic hot water) control managed by CAR v2				
Temperature	Temperature read by the DHW probe				
Boost function (*)	Sets the DHW (Domestic hot water) boost function management:				
	Boost: Off = always off		Off-On-Auto	Off	
	ON = always on				
	Auto = managed as required by the DHW (Domestic hot water) program				
Set management (*)	Sets the DHW (Domestic hot water) set control mode:				
	Auto = the DHW (Domestic hot water) set will be controlled at two levels, according to the DHW (Domestic hot water) program.		Auto-Man	Man	
	Manual = the DHW (Domestic hot water) set will always be fixed at the manual value (regardless of the DHW (Domestic hot water) program)				
Set comfort	Sets comfort set (comfort set will be active during the active time slots of the DHW (Domestic hot water) program if “Set management = Auto” is selected)	10 ÷ 60°C	50°C		
Set economy	Sets reduced set (economy set will be active during the NON active time slots of the DHW (Domestic hot water) program if “Set management = Auto” is selected)	10 ÷ 60°C	30°C		
Set manual	Sets manual set (manual set will be active 24 hours a day if “Set management = Man” is selected)	10 ÷ 60°C	10°C		

(*) See DHW (Domestic hot water) paragraph

Zones Menu.

Press the “Zones” BUTTON  to access a list of variables that enable you to customise use of the zones.

Hereunder is a list of available menus:

ZONE	
Menu item	Description
Zone 1	Defines the operating parameters to manage zone 1 (or the entire system if single-zone).
Zone 2 (*)	Defines the operating parameters to manage the zone 2 (if present).
Zone 3 (*)	Defines the operating parameters to manage the zone 3 (if present).

(*) if present.

INSTALLER

USER

MAINTENANCE/TECHNICIAN

TECHNICAL DATA



The following tables will appear the same also for any Zone 2 and Zone 3.

ZONES/Zone 1	
Menu item	Description
Information	This displays the system operating data
Settings	Defines the operating parameters to manage zone 1
Definition	Defines any further operating parameters to manage zone 1

ZONES/Zone 1/Information		
Menu item	Description	Range
Room temperature (***)	Room temperature read on zone 1	0°C ÷ 50°C
Room Set (**)(***)	Room temperature set on zone 1	5°C ÷ 35°C
Working mode status	Mode set on zone 1	OFF / A-ECO / A-COMF / MAN
Room thermostat status	Status of the room thermostat on zone 1	Open / Close
Set CH	This displays the zone 1 flow set	25°C ÷ 85°C
Plant	Information related to the type and presence or absence of a room probe	



Zone 1 Information Menu is always present regardless of whether or not a CAR^{V2} is connected.

(**) not displayed when the “Req. with room probe” is set to NO

(***) displayed when the zone of interest is associated with a room probe (RF probe,...)

ZONES/Zone 1/Information/Plant		
Menu item	Description	Range
Room probe	This displays or not the presence of the room probe	OFF = No probe
		WIRED = Not used
		RF = Probe present
		OT = CAR V2 presence
Water circuit	If zone board is present, it informs about the type of system in use in the zone.	DIR = Direct circuit
		MIX = Mixed circuit
CH temperature	Zone board absent: the temperature read is the one to the boiler outlet	0°C ÷ 99°C
	Zones control unit present + request for information relating to the mixed zone	

ZONES/Zone 1/Settings

Menu item	Description	Range	Default	Customised value
Function Mode (1)	Sets the zone 1 operating mode	OFF / MAN / AUTO	MAN	
Set AUTO Comfort (2)	Zone 1 room temperature correlated to the active time slots of the zone 1 calendar	10°C ÷ 35°C	20°C	
Set AUTO reduced (2)	Zone 1 room temperature correlated to the NON active time slots of the zone 1 program	5°C ÷ 30°C	16°C	
Set MAN (3)	Zone 1 room temperature that can be activated by selecting the operating mode = manual	5°C ÷ 35°C	20°C	
Weather comp. offset (4)	Zone 1 flow temperature correction in relation to external probe detection	-9°C ÷ 9°C	0°C	
Maximum heating set (5)	Maximum zone 1 flow temperature	20°C ÷ 85°C	85°C	

(1) **Not displayed** if remote device present

(2) **Not displayed** when:

- the “Operating mode” parameter is set to “Man” or “Off”;
- lack or unavailability of room and wireless probes;

(3) **Not displayed** when:

- the “Operating mode” parameter is set to “Auto” or “Off”;
- lack or unavailability of room and wireless probes;

(4) **Not displayed** when:

- the external probe is absent/unavailable
- a room probe is configured
- the “Operating mode” parameter is set to “Off”
- the remote device is present

(5) **Not displayed** when:

- the external probe is present
- a room probe is configured
- the “Operating mode” parameter is set to “Off”

Main Menu.

Press the "MENU" button to access a list of variables that enable you to customise use of the system.

Hereunder is a list of available menus:

MENU	
Menu item	Description
Time and program	Defines the date/time and time operating slots
Information	Display system operating data
Historical alarm code	Displays the list of the last 10 anomalies
Counters	This displays the number of ignitions and the hours of operation of the burner
General settings	Allows selecting the panel operating language, the display operating mode and to access the password-protected menus dedicated to a qualified technician.

MENU/Time and program				
Menu item	Description	Range	Default	Customised value
Date and time	Current date and time setting			
Auto switch to DST	Automatically sets summer time	Yes - No	Yes	
Calendars	Defines the time range for operation in Comfort and Economy mode			
Zone 1 program	Zone 1 time scheduling		CAL3	
Zone 2 program	Zone 2 time scheduling (if present)		CAL3	
Zone 3 program	Zone 3 time scheduling (if present)		CAL3	
DHW Program	DHW operation time programming		CAL3	
Holiday program	Defines the period during which the system disables both hot water heating and room central heating functions. At the end of the set days, the previously active functions will be reset.	Off - 1 ÷ 30 gg	Off	

MENU/Information	
Menu item	Description
Gas type	Gas type display: NG (Methane), LG (L.P.G.), AP (propane air)
Flame signal	Flame signal display
CH temperature	Flow temperature display
DHW temperature	Storage tank/DHW (Domestic hot water) outlet temperature display
Set CH	This displays the set central heating / C.H. temperature set
Set DHW	Set DHW (Domestic hot water) temperature display
External temperature	(Optional)
Input DHW temperature	Not used on this model
CH Return temperature	Return temperature display
CH2 temperature	Safety flow probe display
Common flow probe	(Optional)
Duty pump command	Control signal of the pump duty PWM
Flow pump	System flow rate display
Flow rate	Not used on this model
Fan speed	Fan speed display (rpm)
Boiler exhaust temp.	Flue gas temperature display
Solar storage temp.	Not used on this model
Solar collector temp.	Not used on this model
Maintenance withing	This displays the number of days within which maintenance must be carried out. After the days or with the function deactivated, the line is not displayed
Main board rev. SW	Boiler board sw version display
Firmware version	Display board sw version display

MENU/Historical alarm code	
Menu item	Description
Show alarm	This displays the boiler anomaly history. The size of the anomaly history is equal to 10 anomalies.

MENU/General settings				
Menu item	Description	Range	Default	Customised value
Language	Defines the remote panel operation language		ITA (*)	
Display	It is possible to adjust the contrast and lighting of the display. The lighting (available on two levels) can be automatically selected as fixed or variable during the boiler operation or user access to the display			
Menu access level	Allows the entry of an access code to access the parameter customisation menus according to ones needs (dedicated to a qualified technician)			
User factory settings	Resets the user parameters to default state			

(*) The display leaves the factory set in Italian. To change the display language, see Par. 2.5 in the "USER" chapter, under "Changing the display language".

In case the user restores the factory conditions through "Menu/General settings/User factory settings", the menu will appear in English. Proceed in the following way to restore the desired display language:

- Enter **Menu/General setting/Language**.
- Select the desired language from those available and press OK.

INSTALLER

USER

MAINTENANCE TECHNICIAN

TECHNICAL DATA

2.7 FAULT AND ANOMALY SIGNALS

The boiler indicates a possible anomaly through a code flanked by the symbol of a key “” in the centre of the display and the message “boiler anomaly” at the bottom of the display itself (Fig. 44).

Error Code	Anomaly signalled	Cause	Boiler status/ Solution
01	No ignition block	In the event of request of room central heating or domestic hot water production, the boiler does not switch on within the preset time. Upon appliance commissioning or after extended downtime, it may be necessary to eliminate the block.	Press the Reset button (1)
02	Safety thermostat block (overheating safety device)	During normal operation, if a fault causes excessive overheating internally, the boiler goes into overheating block.	Press the Reset button (1)
03	Flue safety thermostat block	During normal operation, if a fault causes excessive flue gas overheating, the boiler blocks.	Press the Reset button (1)
04	Contacts resistance block	The P.C.B. detects a fault on the gas valve supply. Check its connection. (the anomaly is detected and displayed only in the event of a request).	Press the Reset button (1)
05	Delivery probe fault	The board detects an anomaly on the flow NTC probe.	The boiler does not start (1)
07	Chimney sweep function	The boiler is in chimney sweep operation.	(3)
08	Maximum N° of resets	Number of allowed resets already performed.	The anomaly can be reset 5 times consecutively, after which the function is inhibited for at least one hour. One attempt is gained every hour for a maximum of 5 attempts. By switching the appliance on and off again, the 5 attempts are re-acquired.
10	Insufficient system pressure	Water pressure inside the central heating circuit that is sufficient to guarantee the correct operation of the boiler is not detected.	Check on the boiler pressure gauge that the system pressure is between 1÷1.2 bar and restore the correct pressure if necessary.
12	Storage tank probe anomaly	The board detects an anomaly on the storage tank probe.	The boiler cannot produce domestic hot water (1)
(1) If the shutdown or fault persists, contact an authorised company (e.g. Authorised Service Centre)			
(2) The anomaly can only be verified in the list of errors in the “Information” menu			
(3) Error displayed only on CAR^{V2}			

Error Code	Anomaly signalled	Cause	Boiler status / Solution
15	Configuration error	If the board detects an anomaly or incongruity on the electric wiring, the boiler will not start.	If normal conditions are restored the boiler restarts without having to be reset. Check that the boiler is configured correctly (1)
16	Fan anomaly	This occurs if the fan has a mechanical or electrical fault.	Press the Reset button (1)
20	Parasite flame block	This occurs in the event of a leak on the detection circuit or anomaly in the flame control unit.	Press the Reset button (1)
23	Return probe anomaly	The board detects an anomaly on the return NTC probe.	The boiler always works with the pump at maximum speed (1)
29	Flue probe anomaly	The board detects an anomaly on the flue gas probe.	The boiler does not start (1)
30	Combustion model setting request	The combustion model identification parameter setting is incorrect or does not support the firmware evolution of the combustion control board.	(1)
31	Loss of remote control communication	This occurs if an incompatible remote control is connected, or if communication between the boiler and the remote control is lost or incorrect connection to the terminals.	Disconnect and reconnect the power to the boiler. If the Remote Control is still not detected on re-starting, the boiler will switch to local operating mode, i.e. using the controls on the control panel. Check the correct connection to the terminals (1).
36	IMG Bus communication loss	Communication between the various components is interrupted due to an anomaly on the boiler control unit, on the zone control unit or on the IMG Bus.	The boiler does not satisfy the room heating requests (1).
37	Low power supply voltage value	This occurs when the power supply voltage is lower than the allowed limits for the correct boiler operation.	If normal conditions are restored the boiler restarts without having to be reset (1)
38	Loss of flame signal	This occurs when the boiler is ignited correctly and the burner flame switches off unexpectedly; a new attempt at ignition is performed and if normal conditions are restored, the boiler does not have to be reset.	If normal conditions are restored the boiler restarts without having to be reset (1) (2)
(1) If the shutdown or fault persists, contact an authorised company (e.g. Authorised Service Centre)			
(2) The anomaly can only be verified in the list of errors in the “Information” menu			
(3) Error displayed only on CAR^{V2}			

Error Code	Anomaly signalled	Cause	Boiler status/ Solution
43	Block due to loss of flame signal	This occurs if the "Flame signal loss" error occurs many times in a row within a preset period (38).	Press the Reset button, before restarting, the boiler will run a post-ventilation cycle. (1)
44	Block for exceeding gas valve frequent maximum opening time	This occurs if the gas valve remains open for longer than required for normal operation, without the boiler switching on.	Press the Reset button (1)
45	High T Delta	The boiler detects a sudden, unexpected increase in the ΔT between the flow probe and the system return probe.	The power of the burner is limited to prevent damage to the condensation module and once the right ΔT is restored, the boiler resumes regular operation. Make sure there is water circulating in the boiler, that the pump is configured according to system requirements and that the return probe works properly (1)
46	Intervention of DIM v2 safety thermostat or Low temperature safety thermostat outside the boiler	During normal operation, if an anomaly causes excessive overheating of the flow temperature in low temperature conditions, the boiler blocks.	In this case, after suitable cooling, it is possible to reset the thermostat (see relative instructions sheet) (1)
47	Burner power limitation	Should flue high temperature be detected, the boiler reduces power supplied so as not to damage it.	(1)
48	System flow probe anomaly	The board detects an anomaly on the system flow probe (Optional).	The boiler works with possible system temperature oscillations (1)
51	RF communication failure towards CAR v2 RF	If there is no communication between the boiler and Wireless version CAR, an anomaly is signalled. From this moment, it is only possible to control the system by means of the control panel of the boiler itself.	Check operation of the Wireless CAR, check the battery charge (refer to the relative instructions booklet).
(1) If the shutdown or fault persists, contact an authorised company (e.g. Authorised Service Centre)			
(2) The anomaly can only be verified in the list of errors in the "Information" menu			
(3) Error displayed only on CAR^{v2}			

Error Code	Anomaly signalled	Cause	Boiler status / Solution
59	Electric power supply mains frequency anomaly	The board detects a main supply voltage frequency anomaly.	The boiler does not start (1)
60	Anomaly pump blocked	The pump is stopped due to one of the following causes: Impeller blocked, electrical fault.	Try to unblock the pump as described in the relative section. If normal conditions are restored the boiler restarts without having to be reset (1)
61	Air in circulator pump anomaly	Air is detected inside the pump; the pump cannot work.	Vent the pump and the central heating circuit. If normal conditions are restored the boiler restarts without having to be reset (1)
62	Complete calibration required	Missing calibration is detected by the P.C.B. It may occur in the event the P.C.B. is replaced or if the parameters are altered in the air / gas section, thus requiring "complete calibration".	The boiler does not start (1)
72	Fast calibration required	The P.C.B. detects that some parameters have been altered, thus requiring "fast calibration".	The boiler does not start (1)
73	High deviation between flow probe and safety flow probe	Faulty flow sensor or not correctly inserted.	If normal conditions are restored the boiler restarts without having to be reset (1)
74	Safety flow probe anomaly	The board detects an anomaly on the NTC safety flow probe.	The boiler does not start (1)
77	Combustion control anomaly	Out of range current is detected on the gas valve.	The boiler does not start (1)
78	Combustion control anomaly	High current on the gas valve is detected.	The boiler does not start (1)
(1) If the shutdown or fault persists, contact an authorised company (e.g. Authorised Service Centre)			
(2) The anomaly can only be verified in the list of errors in the "Information" menu			
(3) Error displayed only on CAR^{V2}			

INSTALLER

USER

MAINTENANCE TECHNICIAN

TECHNICAL DATA

Error Code	Anomaly signalled	Cause	Boiler status/ Solution
79	Combustion control anomaly	Reduced current on the gas valve is detected.	The boiler does not start (1)
80	Block - gas valve driver issue	This occurs in the event of malfunctions of the P.C.B. that controls the valve.	Press the Reset button (1)
84	Combustion anomaly (Power reduction in progress)	A low supply pressure is detected on the gas line. As a result the appliance power is limited and the anomaly is reported.	If normal conditions are restored the boiler restarts without having to be reset (1) (2)
87	Block - gas valve control	A malfunction of one of the components that controls the gas valve has been detected.	The boiler does not start (1)
88	Block - gas valve control	A malfunction of one of the components that controls the gas valve has been detected.	The boiler does not start (1)
89	Combustion signal unstable	The flame is unstable due to: presence of flue gas recirculation, wind, unstable gas pressure, unstable fan speed, or due to system malfunction.	The boiler keeps working (1) (2)
90	Combustion signal beyond limit	The combustion signal is beyond the adjustment range required for an extended period of time.	The boiler keeps working (1) (2)
91	Incorrect ignition block	The board has exhausted all possible actions in order to obtain optimal ignition of the burner.	Press the Reset button (1)
92	Fan revs correction limit	The system has exhausted all possible corrections of the number of fan revs.	The boiler keeps working (1) (2)
93	Combustion signal beyond limit	The combustion signal is beyond the adjustment range required for a limited period of time.	The boiler keeps working (1) (2)
94	Combustion anomaly	A problem is detected on the combustion control, which may be due to: gas low pressure, flue recirculation, defective gas valve or P.C.B.	If normal conditions are restored the boiler restarts without having to be reset (1) (2)
(1) If the shutdown or fault persists, contact an authorised company (e.g. Authorised Service Centre)			
(2) The anomaly can only be verified in the list of errors in the “Information” menu			
(3) Error displayed only on CAR^{V2}			

Error Code	Anomaly signalled	Cause	Boiler status/ Solution
95	Combustion signal discontinuous	The system detects a discontinuous combustion signal.	The boiler keeps working (1) (2)
96	Clogged flue	This occurs in the event an obstruction is detected in the flue system.	The boiler does not start (1). If normal conditions are restored the boiler restarts without having to be reset If error 96 appears after the Technician has made changes on the “flue” parameters, it is necessary to perform a “quick calibration”.
98	Block - maximum no. of software errors	The maximum number of software errors possible has been reached.	Press the Reset button (1)
99	General block	A boiler anomaly has been detected.	Press the Reset button (1)
121*	Zone 1 device offline alarm	Low quality or no radio communication between the zone 1 wireless probe and the concentrator.	Check receiver/sensor positioning Check probe battery (1)
122*	Zone 2 device offline alarm	Low quality or no radio communication between the zone 2 wireless probe and the concentrator.	Check receiver/sensor positioning Check probe battery (1)
123*	Zone 3 device offline alarm	Low quality or no radio communication between the zone 3 wireless probe and the concentrator.	Check receiver/sensor positioning Check probe battery (1)
125*	Zone 1 room temperature probe anomaly	Faulty room sensor (resistor open or short circuit).	Replace room probe (1)
126*	Zone 2 room temperature probe anomaly	Faulty room sensor (resistor open or short circuit).	Replace room probe (1)
127*	Zone 3 room temperature probe anomaly	Faulty room sensor (resistor open or short circuit).	Replace room probe (1)
138	Screed heater in progress	Signalling to remote screed heater function devices (except CAR ^{V2}).	(1)
(1) If the shutdown or fault persists, contact an authorised company (e.g. Authorised Service Centre)			
(2) The anomaly can only be verified in the list of errors in the “Information” menu			
(3) Error displayed only on CAR^{V2}			

(*) Errors visible below zone area icons.

INSTALLER

USER

MAINTENANCE TECHNICIAN

TECHNICAL DATA

Error Code	Anomaly signalled	Cause	Boiler status/ Solution
139	Deaeration in progress	Signalling to remote venting function devices (except CAR ^{V2}).	(1)
141	Alarm due to connection to outdated zones control unit	The zones control unit does not have suitable firmware for communicating with the boiler.	Update zones control unit fw (or replace the board with the latest version) (1)
142	Dominus Offline Alarm	The Dominus is disconnected or not powered. No communication between Dominus and the boiler.	Check that the Dominus is correctly connected and powered Replace the Dominus or the display board (1)
178	Anti-legionella cycle not successful	The anti-legionella cycle was not completed successfully within a preset time.	Check the set anti-legionella time. Check the thermal exchange to the storage tank. The error is reset by changing the operating mode, or by pressing the ON - OFF button (1).
300*	RF address 0 concentrator off-line alarm	Lack of communication on BUS (wires) between concentrator with address "0" and boiler.	Check concentrator-boiler-display board connection wiring Check correct association Replace concentrator board or display board (1)
301*	RF address 1 concentrator off-line alarm	Lack of communication on BUS (wires) between concentrator with address "1" and boiler.	Check concentrator-boiler-display board connection wiring Check correct association Replace concentrator board or display board (1)
302*	RF address 2 concentrator off-line alarm	Lack of communication on BUS (wires) between concentrator with address "2" and boiler.	Check concentrator-boiler-display board connection wiring Check correct association Replace concentrator board or display board (1)
(1) If the shutdown or fault persists, contact an authorised company (e.g. Authorised Service Centre)			
(2) The anomaly can only be verified in the list of errors in the "Information" menu			
(3) Error displayed only on CAR^{V2}			

(*) Errors visible below zone area icons.



The reset of the error signal (following a solving operation) can take up to 10 minutes. It is recommended to "force" the communication between the probe and concentrator by briefly pressing the probe button; in this way the RF communication between the two devices will be forced and the error signal will be quickly cancelled.

2.8 BOILERSWITCH-OFF

Switch the boiler off by putting it in “off” mode, disconnect the onnipolar switch outside of the boiler and close the gas cock upstream from the appliance.

Never leave the boiler switched on if left unused for prolonged periods.

2.9 RESTORE CENTRAL HEATING SYSTEM PRESSURE

1. Periodically check the system water pressure (the boiler’s pressure gauge hand must indicate a value between 1 and 1.2 bar).
2. If the pressure falls below 1 bar (with the system cold) restore normal pressure via the valve located at the bottom of the boiler (Fig. 50).
3. Close the cock after the operation.
4. If the pressure reaches values around 3 bar, there is a risk of tripping the safety valve (in this case, remove water from a radiator air vent valve until a pressure of 1 bar is achieved, or ask for assistance from professionally qualified personnel).
5. In the event of frequent pressure drops, contact qualified staff for assistance to eliminate the possible system leakage.

Bottom view:

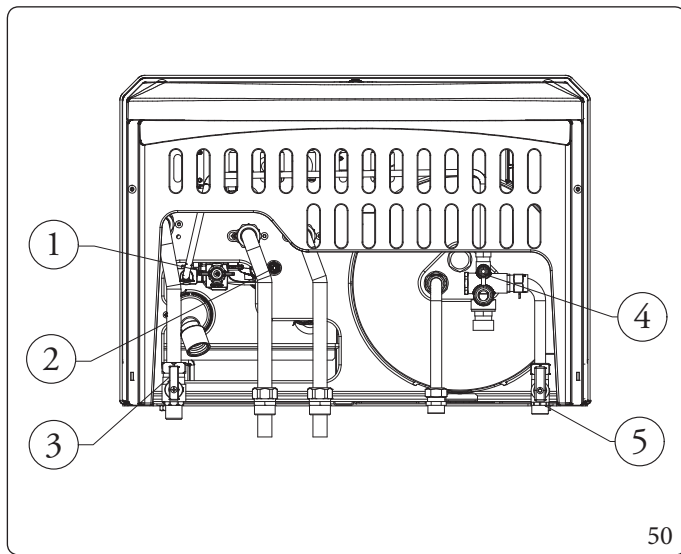

Key (Fig. 50):

- | | | |
|---|---|-----------------------------|
| 1 | - | System filling valve |
| 2 | - | System draining valve |
| 3 | - | GAS cock |
| 4 | - | Storage tank draining valve |
| 5 | - | Cold water inlet cock |

2.10 DRAINING THE SYSTEM

To drain the boiler, use the special draining valve (Fig. 50).

Before draining, ensure that the filling cock is closed.



If fluid containing glycol was added to the system circuit, make sure it is recovered and disposed of in accordance with standard EN 1717.

2.11 EMPTYING THE D.H.W. CIRCUIT

To do this, always close the domestic cold water inlet upstream of the appliance.

Open any domestic hot water tap to discharge the pressure from the circuit.

2.12 STORAGE TANK DRAINING

To drain the storage tank, use the relevant storage tank draining valve (Fig. 50).



Before performing this operation, close the boiler cold water inlet valve and open any DHW system hot water valve in order to allow the inlet of air into the storage tank.

2.13 ANTIFREEZE PROTECTION

The boiler has an antifreeze function that switches the burner on automatically when the temperature falls below 4°C (standard protection to minimum temperature of 0°C).

In order to guarantee the integrity of the appliance and the domestic hot water heating system in zones where the temperature falls below zero, we recommend the central heating system is protected using anti-freeze liquid and installation of the Immergas Antifreeze Kit in the boiler.

All information relative to the antifreeze protection is stated in (Parag. 1.4).

2.14 PROLONGED INACTIVITY

In case of prolonged inactivity (e.g. second home), we recommend:

1. to switch off the power supply;
2. to completely empty the heating circuit and the boiler D.H.W. circuit. In systems that are drained frequently, filling must be carried out with suitably treated water to eliminate hardness that can cause lime-scale.

2.15 CLEANING THE CASE

1. Use damp cloths and neutral detergent to clean the boiler casing.



Never use abrasive or powder detergents.

2.16 PERMANENT SHUTDOWN

In the event of permanent shutdown of the boiler, contact professional staff for the procedures and ensure that the electrical, water and gas supply lines are shut off and disconnected.

3 INSTRUCTIONS FOR MAINTENANCE AND INITIAL CHECK

3.1 GENERAL RECOMMENDATIONS



Operators who install and service the appliance must wear the personal protective equipment (PPE) required by applicable law.
The list of possible PPE is not complete as they are indicated by the employer.



Before carrying out any maintenance work, make sure that:

- you have disconnected the power to the appliance;
- you have closed the gas cock;
- you have discharged the pressure from the system and domestic hot water circuit.



If additional documentation needs to be consulted for extraordinary maintenance, contact the Authorised After-Sales Service.



Supply of spare parts

The device's warranty shall be rendered null and void if unapproved or unsuitable parts are used for maintenance or repairs. These will also compromise the product's compliance, and the said product may no longer be valid and fail to meet the current regulations. In regard to the above, only use original Immergas spare parts when replacing components.

3.2 INITIAL CHECK

To commission the boiler:

- ensure that the type of gas used corresponds to the boiler settings (the type of gas appears on the display on first electrical power supply, on the data nameplate or, with the display already on, with the following sequence: MENU - Information - Ok);
- check connection to a 230V-50Hz power mains, correct L-N polarity and the earthing connection;
- make sure the central heating system is filled with water and that the boiler manometer indicates a pressure of 1±1.2 bar;
- switch the boiler on and ensure correct ignition;
- check the Δp gas values in domestic hot water and central heating modes;
- check the proper calibration of the number of fan revolutions;
- check the CO₂ flow rate in the flue:
 - maximum
 - intermediate
 - minimum
- the values comply with the relevant tables (Par. 3.3);
- check activation of the safety device in the event of no gas, as well as the relative activation time;
- check activation of the main switch located upstream of the boiler;
- check that the intake and/or exhaust terminals are not blocked;
- ensure activation of all adjustment devices;
- seal the gas flow regulation devices (if the settings are changed);
- ensure production of domestic hot water;
- check the tightness of the hydraulic circuits;
- check ventilation and/or aeration of the installation room where provided.



Even if just one single safety check provides a negative result, do not commission the system.

INSTALLER

USER

MAINTENANCE TECHNICIAN

TECHNICAL DATA

3.3 YEARLY APPLIANCE CHECK AND MAINTENANCE



The following checks and maintenance should be performed once a year to ensure operation, safety and efficiency of the appliance over time.

INSTALLER

- Clean the flue side of the heat exchanger.
- Clean the main burner.
- Check the correct positioning, integrity and cleanliness of the detection and ignition electrode; remove any oxide present.
- If deposits are detected in the combustion chamber they must be removed and the heat exchanger coils must be cleaned using nylon or broomcorn brushes; it is forbidden to use brushes made of metal or other materials that may damage the combustion chamber. It is also forbidden to use alkaline or acid detergents.
- Check the integrity of the insulating panels inside the combustion chamber and if damaged replace them.
- Visually check for water leaks or oxidation from/on connections and traces of condensate residues inside the sealed chamber.
- Check the contents of the condensate drain trap.
- Visually check that the siphon is properly filled with condensate and top it up if necessary.

USER

- Check that there are no material residues in the condensate drain siphon clogging the condensate passage; also check that the entire condensate drainage circuit is clear and efficient.
- In the event of obstructions (dirt, sediment, etc.) with consequent leakage of condensate in the combustion chamber, one must replace the insulating panels.
- Check that the burner and gas manifold seal gaskets are intact and perfectly efficient, otherwise replace them. In any case the gaskets must be replaced at least every two years, regardless of their state of wear.
- Check that the burner is intact, that it has no deformations or cuts and that it is properly fixed to the combustion chamber lid; otherwise it must be replaced.
- Visually check that the water safety drain valve is not blocked.
- Check that, after discharging the system pressure and bringing it to zero (read on boiler pressure gauge), the expansion vessel pressure is at 1.0 bar.
- Check that the system static pressure (with system cold and after refilling the system by means of the filling valve) is between 1 and 1.2 bar.
- Check visually that the safety and control devices have not been tampered with and/or shorted, in particular:
 - temperature safety thermostat;
 - system pressure switch.

MAINTENANCE TECHNICIAN

- Check the conservation and integrity of the storage tank magnesium anode.
- Check the condition and integrity of the electrical system and in particular:
 - The power cables must be inside the cable fixings;
 - There must be no traces of blackening or burning.
- Check correct lighting and operation.
- Check the CO₂ by using the chimney sweep function at the three reference heat outputs, using the parameters entered in the following tables. Should values out of the indicated tolerance range be detected, check the integrity of the ignition / detection electrodes and, if required, change them, also changing the relative gasket. At this point, activate the “complete calibration” function.
- Ensure correct calibration of the burner in domestic water and central heating phases.
- Check correct operation of control and adjustment devices and in particular:
 - system regulation probes intervention;
 - Domestic hot water control thermostat intervention.
- Check sealing efficiency of gas circuit and the internal system.
- Check the intervention of the device against no gas ionisation flame control. Intervention time must be less than 10 seconds.
- Check the non-return valve on the flue gas in installations C10 - C12.

TECHNICAL DATA

Victrix Zeus Superior 25

Gas type	CO ₂ to nominal Q.	CO ₂ to ignition Q.	CO ₂ to minimum Q.
G20	8.8% (±0,5)	8.8% (±0,5)	8.8% (±0,5)
G31	10.3% (±0,5)	9.9% (±0,5)	9.9% (±0,5)

Gas type	O ₂ at Nominal Q.	O ₂ at Ignition Q.	O ₂ at Minimum Q.
G20	5,2% (±0,9)	5,2% (±0,9)	5,2% (±0,9)
G31	5,2% (±0,7)	5,6% (±0,7)	5,8% (±0,7)

Victrix Zeus Superior 30

Gas type	CO ₂ to nominal Q.	CO ₂ to ignition Q.	CO ₂ to minimum Q.
G20	8.8% (±0,5)	8.8% (±0,5)	8.8% (±0,5)
G31	10.5% (±0,5)	10.3% (±0,5)	10.3% (±0,5)

Gas type	O ₂ at Nominal Q.	O ₂ at Ignition Q.	O ₂ at Minimum Q.
G20	5,2% (±0,9)	5,2% (±0,9)	5,2% (±0,9)
G31	5,2% (±0,7)	5,2% (±0,7)	5,2% (±0,7)

Victrix Zeus Superior 35

Gas type	CO ₂ to nominal Q.	CO ₂ to ignition Q.	CO ₂ to minimum Q.
G20	8.8% (±0,5)	8.8% (±0,5)	8.8% (±0,5)
G31	10.3% (±0,5)	10.3% (±0,5)	10.3% (±0,5)

Gas type	O ₂ at Nominal Q.	O ₂ at Ignition Q.	O ₂ at Minimum Q.
G20	5,2% (±0,9)	5,2% (±0,9)	5,2% (±0,9)
G31	5,2% (±0,7)	5,2% (±0,7)	5,2% (±0,7)



In addition to yearly maintenance, one must also check the energy efficiency of the thermal system, with frequency and procedures that comply with the indications of the technical regulations in force.

INSTALLER

USER

MAINTENANCE/TECHNICIAN

TECHNICAL DATA

3.4 HYDRAULIC DIAGRAM

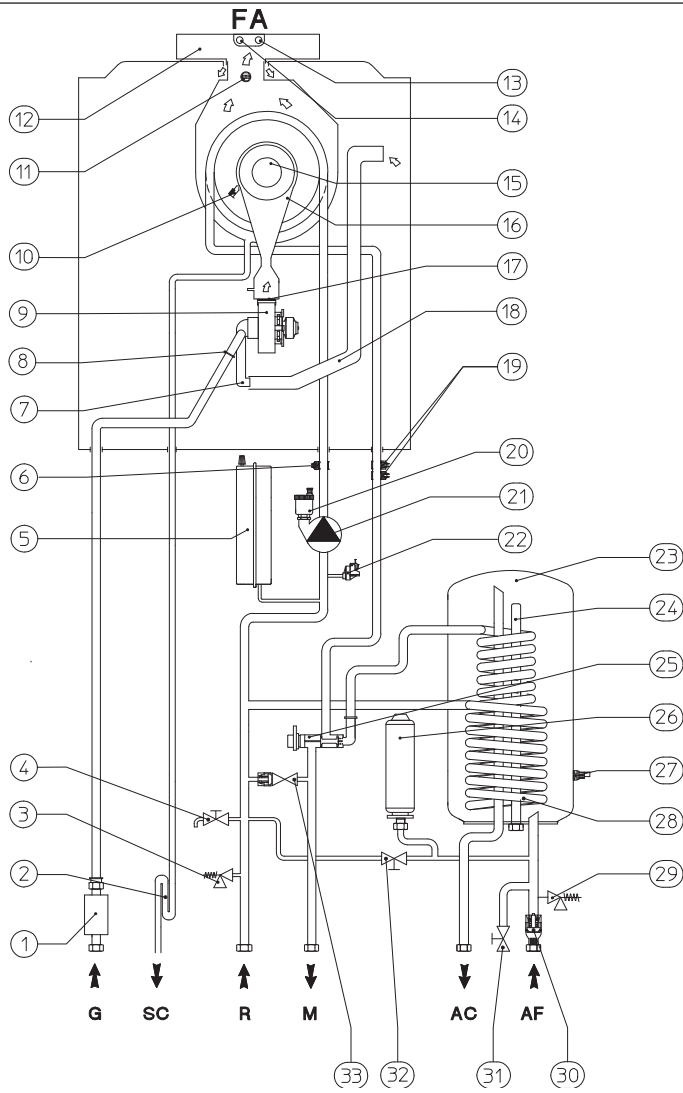

51

Key (Fig. 51):

- | | | | |
|----|--|----|---|
| 1 | - Gas valve | 21 | - Boiler circulating pump |
| 2 | - Condensate drain trap | 22 | - System pressure switch |
| 3 | - 3 bar safety valve | 23 | - Stainless steel storage tank |
| 4 | - System draining cock | 24 | - Magnesium anode |
| 5 | - System expansion vessel | 25 | - 3-way valve (motorised) |
| 6 | - Return probe | 26 | - Domestic hot water expansion vessel |
| 7 | - Air / gas mixer | 27 | - D.H.W. probe |
| 8 | - Gas nozzle | 28 | - Stainless steel coil for storage tank |
| 9 | - Fan unit with non-return valve on the flue gas | 29 | - 8 bar safety valve |
| 10 | - Ignition/detection electrode | 30 | - Cold water inlet non-return valve |
| 11 | - Double flue probe sensor | 31 | - Storage tank draining valve |
| 12 | - Flue hood | 32 | - System filling cock |
| 13 | - Flue sample point | 33 | - By-pass |
| 14 | - Air sample point | | |
| 15 | - Burner | G | - Gas supply |
| 16 | - Air / gas manifold | AC | - Domestic hot water outlet |
| 17 | - Non-return valve on flue gas | AF | - Domestic hot water inlet |
| 18 | - Air intake pipe | SC | - Condensate drain |
| 19 | - Flow probes | M | - System flow |
| 20 | - Air vent valve | R | - System return |

INSTALLER

USER

MAINTENANCE TECHNICIAN

TECHNICAL DATA

3.5 WIRING DIAGRAM

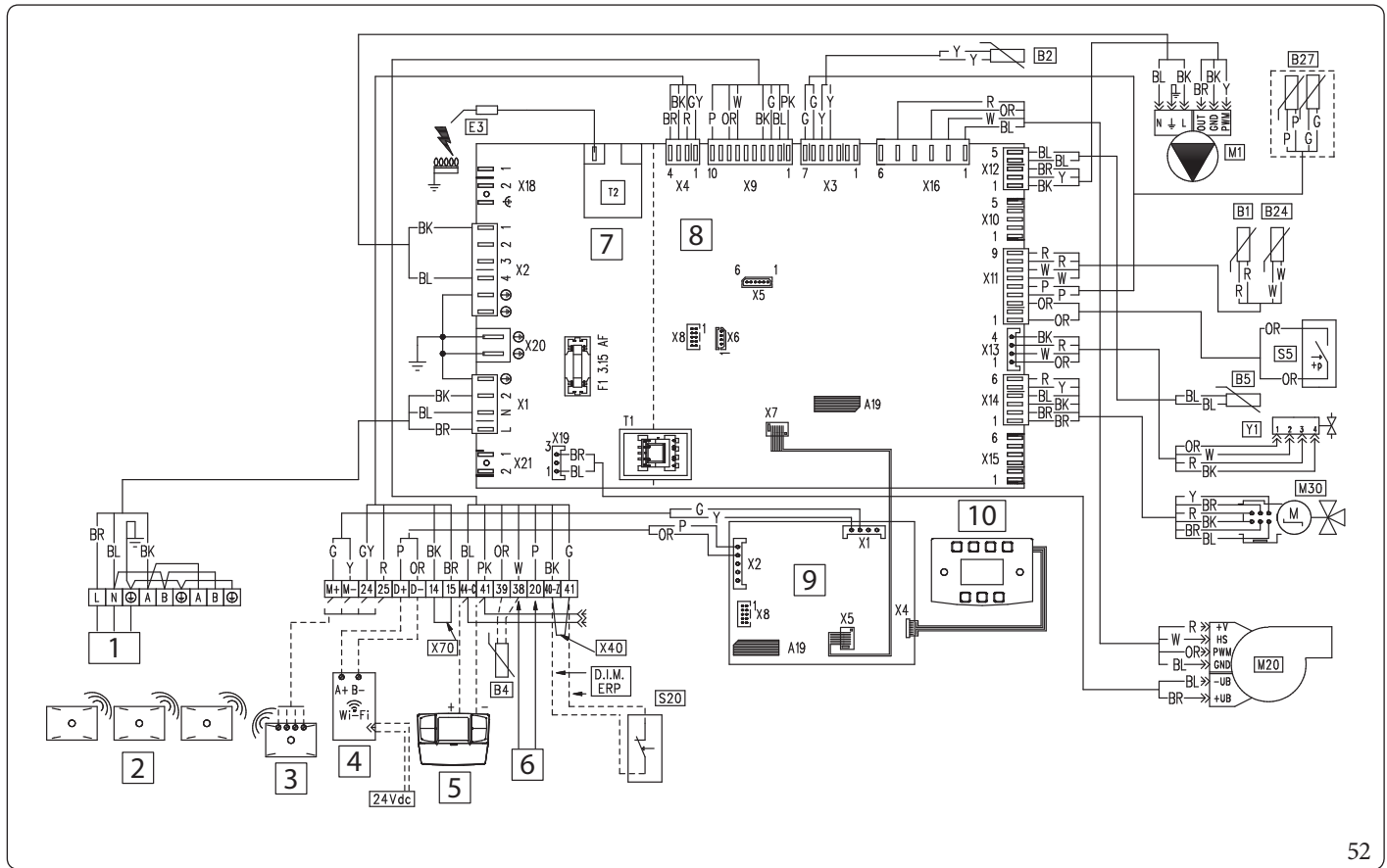

Key (Fig. 52):

- A19 - Removable memory
- B1 - Flow probe
- B2 - D.H.W. probe
- B4 - External probe (optional)
- B5 - Return probe
- B24 - Safety flow probe
- B27 - Double flue probe sensor
- E3 - Ignition and detection electrode
- M1 - Boiler circulating pump
- M20 - Fan
- M30 - Three-way stepper motor
- S20 - Room thermostat (optional)
- S5 - System pressure switch
- T1 - Boiler P.C.B. transformer
- T2 - Ignition transformer
- X40 - Room thermostat jumper
- X70 - Safety thermostat (low temperature) jumper
- Y1 - Gas valve

Colour code key (Fig. 52):

- BK - Black
- BL - Blue
- BR - Brown
- G - Green
- GY - Grey
- OR - Orange
- P - Purple
- PK - Pink
- R - Red
- W - White
- Y - Yellow

Any room thermostat or ON-OFF must be connected to terminals 40 and 41 eliminating jumper X40.

Any CAR^{V2} must be connected to terminals 44 and 41 complying with the polarity **without eliminating jumper X40.**

Key (Fig. 52):

- 1 - 230 Vac 50Hz Power supply
- 2 - Wireless room probes (optional)
- 3 - Wireless concentrator (optional)
- 4 - Dominus (optional)
- 5 - (CAR^{V2}) (optional)
- 6 - Configurable contact or System flow probe
- 7 - 230 V connections
- 8 - Low voltage connections
- 9 - Display board
- 10 - Capacitive keyboard

INSTALLER

USER

MAINTENANCE TECHNICIAN

TECHNICAL DATA

3.6 REMOVABLE MEMORY



Replacing the memory must be carried out after disconnecting all electrical connection of the P.C.B.

P.C.B.

The P.C.B. is equipped with a removable memory (Ref. 2 Fig.53) which records all operation parameters and boiler customisations. Should the P.C.B. be replaced, you can use the memory of the replaced board again, so it is not necessary to reconfigure the appliance.

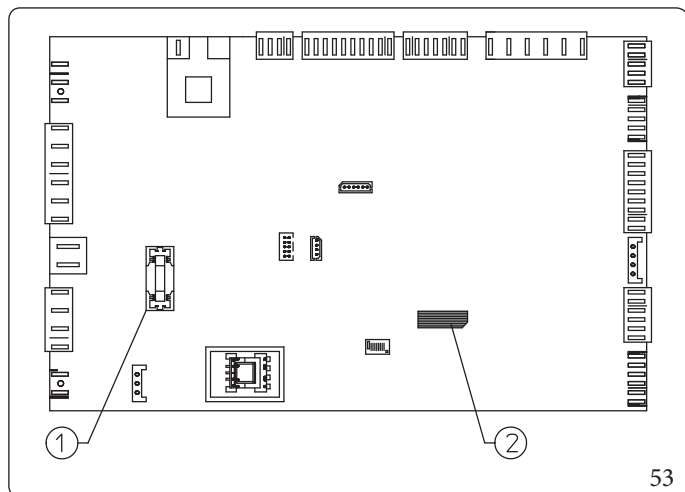

Key (Fig. 53):

- 1 - Fuse 3.15 quick 250 V
- 2 - Grey removable memory (A19)

Display board

The display board is equipped with a removable memory (Ref. 1 Fig.54) which records all operation parameters and customisations of the display, wireless probes, Dominus and timer maintenance.

Should the display board be replaced, you can use the memory of the replaced board again so it is not necessary to reconfigure the appliance.

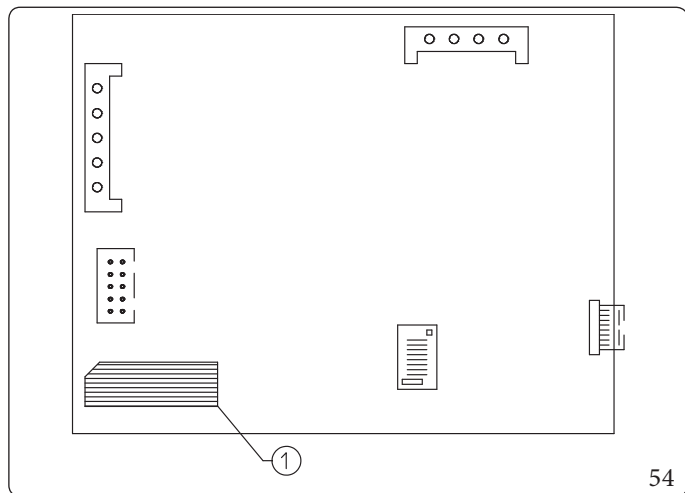

Key (Fig. 54):

- 1 - Black removable memory (A19)

3.7 TROUBLESHOOTING



Maintenance operations must be carried out by an authorised company (e.g. Authorised After-Sales Technical Assistance Centre).

Red pump LED

There can be three possible causes for this anomaly:

Trouble	Possible causes	Solutions
Low power supply voltage	After about 2 seconds, the LED switches from green to red and the pump stops.	Wait for the power supply voltage to rise; when the pump restarts, the LED will turn green again with a delay of about one second. Note: The flow rate decreases as the supply voltage decreases.
Rotor seized	Powering the pump with the rotor seized, after about 4 seconds the LED switches from green to red,	Carefully act on the screw in the middle of the head to manually release the crankshaft; circulation starts up immediately after the rotor is released and the LED switches from red to green after about 10 seconds.
Electrical error		Check that there is no fault on the pump (on its wiring or electronics).

Trouble	Possible causes	Solutions
Smell of gas	Caused by leakage from gas circuit pipelines.	Check sealing efficiency of gas intake circuit.
Irregular combustion or noisiness	Dirty burner, clogged primary heat exchanger, incorrect combustion parameters, intake-exhaust terminal not correctly installed.	Check the indicated components.
Non-optimal ignition of first ignitions of the burner.	The first ignitions of the burner (after calibration) may not be optimal.	The system automatically adjusts the burner ignition until the best ignition conditions are found.
Heat exchanger blocked.	Obstruction of the siphon.	Check that there are no residues of material blocking the flow of condensate.
Abnormal noises in the system	Air in the system.	Check the opening of the cap of the air vent valve (Par. 1.34). Make sure the system pressure and expansion vessel pre-charge values are within the set limits. The factory-set pressure values of the expansion vessel must be 1.0 bar, the value of system pressure must be between 1 and 1.2 bar.
Poor production of D.H.W.	DHW heat exchanger clogged.	Contact the Authorised After-Sales Assistance Service that has procedures to clean the D.H.W. heat exchanger.

3.8 ACCESS RESERVED TO SERVICE

To enter the boiler menu reserved for Service:

MENU/General settings/Menu access level

To activate the access reserved to Service, follow the above path; upon “Access code request”, enter code 1122 (using the “DHW (Domestic hot water) set” and “Central heating / C.H. set” knobs) and press “OK”, then the “Access level” menu will open where it is possible to select the “Service” access type. The authentication as Service gives access to the parameters reserved for a qualified Technician.



As long as you continue navigating the menu, access as Service remains active.

Returning to the main screen (RESET), the Service access will remain active for 4 minutes, then it will automatically go back to User level.

To manually go back to User level, simply type the password following the procedure described above and set User again.

If the boiler turns off and on again, the menu will automatically go back to User level.

3.9 CONVERTING THE BOILER TO OTHER TYPES OF GAS.



The gas conversion operation must be carried out by an authorised company (e.g. Authorised Technical Assistance Service).

To convert to another type of gas the following operations are required:

MENU/Service/Boiler/Combustion

- In the "Combustion" window, modify and confirm the type of gas on the line "Gas type": "nG" for methane gas, "LG" for LPG gas and "AP" for propane air (Par. 2.6).
- Carry out complete calibration (Par. 3.11); during the procedure check and, if necessary, correct the CO₂ value.
- Upon completing the conversion, apply the sticker regarding the modified gas content onto the data nameplate in the connection box.



The pressure testers used for calibration should be perfectly closed and there should be no leaks from the gas circuit.

Checks following conversion to another type of gas.

These adjustments must be made with reference to the type of gas used, following the indications given in the table (Par. 4.2).

After having made sure that the conversion is complete and that the calibration has been successful, you must make sure that:

- there is no flame in the combustion chamber;
- the burner flame is not too high or low and that it is stable (does not detach from burner);



Maintenance operations must be carried out by an authorised company (e.g. Authorised After-Sales Technical Assistance Centre).



Risk of material damage after using sprays and liquids to search for leaks

Leak sprays and liquids clog the reference hole P.Ref. (Fig. 55) of the gas valve, damaging it irreparably.

During installation and maintenance, do not use spray or liquids in the upper area of the gas valve (side referring to the electric connections).

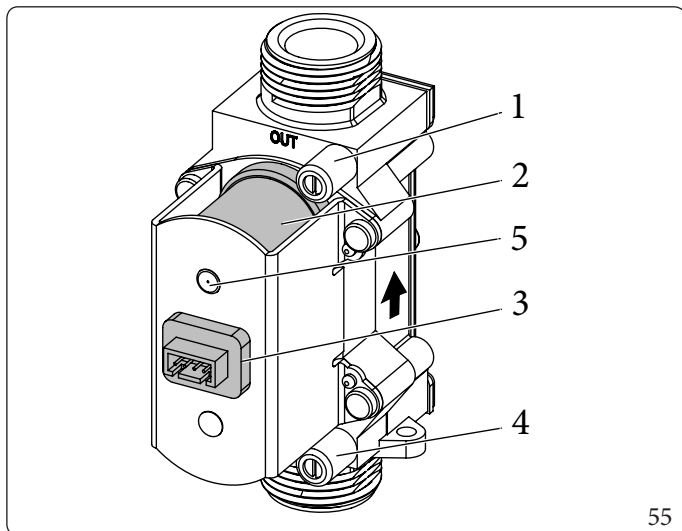

Key (Fig. 55):

- 1 - Gas valve outlet pressure point
- 2 - Coil
- 3 - Wiring connector
- 4 - Gas valve inlet pressure point
- 5 - P.Ref. (Reference pressure)

3.10 CALIBRATION TYPE INVOLVING THE REPLACEMENT OF A COMPONENT.

When performing extraordinary maintenance on the boiler, involving the replacement of a component, such as the P.C.B. (if the removable memory is not put into the replacement board) or components in the air, gas and flame control circuits, the boiler will need to be calibrated.

Select the type of calibration to be carried out according to the table below.

Component replaced	Type of calibration required
Gas valve	Quick calibration
Fan	Quick calibration
Burner	Complete calibration with CO ₂ check
Ignition / detection electrode	Complete calibration with CO ₂ check
P.C.B. (New virgin P.C.B. without removable memory recovery)	Reset the parameters Complete calibration with CO ₂ check
P.C.B. (Recovery of the removable memory with the boiler parameters set from the replaced board)	No calibration required.

3.11 COMPLETE CALIBRATION FUNCTION



Before carrying out complete calibration, ensure that all the requirements indicated in the relevant paragraphs have been met (Par. 1.28 and 1.29).

In the event of anomaly “62” or “72” (Par. 2.7) the boiler cancels any requests by itself.

During the various calibration stages, the CO₂ value can be checked and possibly corrected as described in (Par. 3.12).

The energy produced during the function is disposed of on the central heating circuit / C.H. circuit if a DHW (Domestic hot water) request is not activated; check that any valves on the system not managed by the boiler are open.

To dispose of all the energy on the domestic hot water, open the hot water tap and set the DHW (Domestic hot water) set to maximum before activating the function.

The calibration procedure involves various stages:

- nominal heat output calibration;
- intermediate heat output ignition calibration;
- minimum heat output calibration;

The complete calibration function offers a maximum time of stay within the Calibration Menu of 20 minutes counted after the last action on the display keyboard.

After this time, the function ends, showing the message "Complete calibration".

The Calibration completed window will be automatically abandoned after 60 seconds (to display the main window); if you want to exit the "Complete calibration" message in advance, press the “OK” button.

Complete calibration activation procedure.

Select the Summer or Winter mode by accessing the menu as “Service” user:

Menu/Service/Special Function/Complete calibration



If Antifreeze mode is selected, the function cannot be activated.

In the attempt of activating the function under impossible conditions, the text "Way not compatible" will be displayed.

Complete calibration	
Calibration Phase	max...
Combustion Set	◆ 23
Power perc.	0%
CH temperature	25°C
Flame	Off
Central Heating active	

56

- Calibration Phase: indicates the phase of calibration in progress and the stability connection on the combustion;
- Combustion Set: indicates the combustion set value in progress; if the text is highlighted, the value can be changed using the “Set Central heating / C.H.” knob;
- Power perc.: indicates (from 0 to 100%) the power supplied by the burner;
- CH temperature: indicates the thermal module outlet temperature;
- Flame: indicates the presence of a flame (thus the ignition of the burner)

The text indicating the circuit on which the energy produced is discharged appears at the bottom of the display ("Central Heating active" or "Domestic hot water active")

Nominal heat

The Calibration function is automatically activated when entering the menu window.

Initially "Calibration Phase max" appears, meaning that the boiler is performing the nominal power calibration phase.

After the first moments of burner ignition, "Calibration Phase max<", appears meaning that the boiler has detected and stored the minimum parameters necessary for appliance ignition (it is possible to force the end of calibration by pressing "RESET").

To check and correct the Co₂ values, continue waiting for the combustion set for nominal power to be engaged. After the engaging is complete, "Calibration Phase max ok" appears and the belowline "Combustion Set" is highlighted at the same time.



Under these conditions, the combustion value (Co₂) linked to the supply of maximum nominal power can be measured (Par. 3.12)

Complete calibration	
Calibration Phase	max ok
Combustion Set	↕ 23
Power perc.	100%
CH temperature	51°C
Flame	On
Central Heating active	

57

If the Co₂ value is not that indicated in the table (Par. 4.2), edit the value as described in the paragraph (Par. 3.12).

When the combustion value measured on the nominal power is correct, request the advancement of the procedure to the next phase (intermediate ignition power) by pressing the "OK" button "Calibration Phase max ok".

Ignition intermediate heat output

Once the nominal heat output calibration is confirmed, the boiler is calibrated with the intermediate heat output (or ignition heat output).

The beginning of the intermediate phase is displayed with "Calibration Phase med...", it means that the boiler is adjusting the intermediate power.

To check and correct the Co₂ values, continue waiting for the combustion set for intermediate power to be engaged. After the engaging is complete, "Calibration Phase ok" appears and the belowline "Combustion Set" is highlighted at the same time.



Under these conditions, the combustion value linked to the supply of intermediate power can be measured (Par. 3.12)
Any corrections to the intermediate combustion are linked to the same actions illustrated for the nominal power.

Complete calibration	
Calibration Phase	med ok
Combustion Set	↕ 30
Power perc.	23%
CH temperature	43°C
Flame	On
Central Heating active	

58

If the Co₂ value is not that indicated in the table (Par. 4.2), edit the value as described in the paragraph (Par. 3.12).

When the combustion value measured on the intermediate power is correct, request the advancement of the procedure to the next phase (minimum power) by pressing OK "Calibration Phase ok".

Minimum heat output

After confirming the intermediate power calibration, the boiler is calibrated at minimum power.

The beginning of the minimum phase is displayed with "Calibration Phase min...", it means that the boiler is adjusting the minimum power.

To check and correct the Co₂ values, continue waiting for the combustion set for minimum power to be engaged. After the engaging is complete, "Calibration Phase min ok" appears and the below line "Combustion Set" is highlighted at the same time.



Under these conditions, the combustion value linked to the supply of minimum power can be measured (Par. 3.12)
Any corrections to the minimum combustion are linked to the same actions illustrated for the nominal power.

Complete calibration	
Calibration Phase	min ok
Combustion Set	↕ 64
Power perc.	0 %
CH temperature	24°C
Flame	On
Central Heating active	

59

If the Co₂ value is not that indicated in the table (Par. 4.2), edit the value as described in the paragraph (Par. 3.12).

When the combustion value measured on the minimum power is correct, request the end of the procedure by pressing the "OK" "Calibration Phase min ok" button.

The end of the function is accompanied by the window "Complete calibration".

3.12 CO₂ REGULATION



During the complete calibration (Par. 3.11) it is possible to modify the CO₂ values.

In order to have an exact value of CO₂ in the flue gas, the technician must insert the sampling probe into the well to the bottom



In case of calibration for propane air, select the analyser in LPG gas mode.

Check that the CO₂ value is the one indicated in the table (Par. 4.2), (considering a maximum tolerance of $\pm 0.2\%$), otherwise change the value as described below:

Complete calibration	
Calibration Phase	max ok
Combustion Set	↕ 22
Power perc.	99%
CH temperature	53°C
Flame	On
Central Heating active	

60

The modification takes place only if the line "Combustion Set" is highlighted; using the "Set central heating / C.H." knob, change the "Combustion Set" value then press "OK" to confirm the new value.



Wait for the text "max ok" "med ok" or "min ok" to appear before checking the combustion linked to the new value based on the phase in which the change is made.

3.13 QUICK CALIBRATION

This function allows you to calibrate the boiler automatically without requiring or giving the possibility to alter the parameters. Typically, the "quick calibration" is used after changing the flue type parameters in the menu, which creates the "72" anomaly or is necessary in case of component replacement (Par. 3.10).



Before carrying out the fast calibration, ensure that all the requirements indicated in the relevant paragraphs have been met (Par. 1.28 - 1.29).

The energy produced during the function is disposed of on the central heating circuit / C.H. circuit if a the storage tank is at temperature; check that any valves on the system not managed by the boiler are open.

To dispose of all the energy on the domestic hot water, open the hot water tap and set the DHW (Domestic hot water) set to maximum before activating the function.

Select the Summer or Winter mode by accessing the menu as "Service" user:

Menu/Service/Special Function/Fast calibration



If Antifreeze mode is selected, the function cannot be activated.

In the attempt of activating the function under impossible conditions, the text "Way not compatible" will be displayed.

Once the function is active, the boiler sequentially carries out the procedures required to calibrate the appliance with the nominal, intermediate and minimum heat output values.

Fast calibration	
Calibration Phase	max ...
Combustion Set	--
Power perc.	0%
CH temperature	26°C
Flame	Off
Central Heating active	

61

- Calibration Phase: indicates the phase of calibration in progress and the stability connection on the combustion;
- Combustion Set: value not compiled during quick calibration";
- Power perc.: indicates (from 0 to 100%) the power supplied by the burner;
- CH temperature: indicates the thermal module outlet temperature;
- Flame: indicates the presence of a flame (thus the ignition of the burner)

The text indicating the circuit on which the energy produced is discharged appears at the bottom of the display ("Central Heating active" or "Domestic hot water active")

The Calibration function is automatically activated when entering the menu window.

Initially "Max procedure phase..." appears, meaning that the boiler is performing the nominal power calibration phase.

After the first moments of burner ignition, "Max procedure phase <" appears meaning that the boiler has detected and stored the minimum parameters necessary for appliance ignition (it is possible to force the end of calibration by pressing "RESET").

The advancement is automatic; however, the quick calibration window makes the various phases known:

- Calibration Phase max
- Calibration Phase med
- Calibration Phase min

The "Combustion Set" line is not managed, as it is not possible to operate to modify its value.

3.14 FLUE TEST

The end of the function is accompanied by the window "Calibration completed"



Before performing the test, ensure that the condensate drain trap has been filled correctly and check that there are no obstructions in the air intake circuit and flue exhaust and that the sealed chamber is perfectly closed and the flue has already been installed.

The Flue Test activation command is available in the Menu (with Service reserved access) at the following address:

Menu/Service/Special function/Test flue

To activate the flue test, enter the "Test flue" page and on the first line, activate the Test by selecting "Start".

To end the flue test, select the "Stop" item on the first line.

To define the value to set in the "Flue Length min" parameter, detect the parameters during the "Test flue".

The appliance remains in this mode for a maximum period of 15 minutes, keeping the fan speed constant.

The function ends after 15 minutes, or by selecting "Stop".

Check the ΔP between the two pressure test outlets (Ref. 14, Fig. 43) and set the parameter "Flue length" according to the values shown in the tables below:

Victrix Zeus Superior 25	
Menu/Assistance/Boiler/Flue	Pressure
Min	< 75 Pa
Med	75 ÷ 120 Pa
Max	120 ÷ 210 Pa
Value detected on first check	

Victrix Zeus Superior 30 - 35	
Menu/Assistance/Boiler/Flue	Pressure
Min	< 122 Pa
Med	122 ÷ 183 Pa
Max	184 ÷ 300 Pa
Value detected on first check	



Examinations are carried out by sealing the holes provided to analyse the flues, making them pneumatically sealed.



Should there be a boiler malfunction, you can carry out a flue test to check that there are no obstructions in the flue system. Different values to those indicated in the previous tables indicate a flue system malfunction, especially a flue system with excessive load losses or obstructed system.

3.15 PARAMETERS AND INFORMATION MENU

Navigation diagram within the boiler display

There are 3 Settings menus (Fig. 44):

DHW (Domestic hot water): accessible by pressing the domestic hot water button (2);

Zones: accessible by pressing the zone button (3);

General settings menu: accessible by pressing the menu button (18).



Some menu settings appear only when the options are actually connected and working.

“DHW (Domestic hot water)” Menu.

Press the “DHW (Domestic hot water)” button to access a list of variables that enable you to customise use of the DHW (Domestic hot water).

Hereunder is a list of available menus:

DHW settings				
Menu item	Description	Range	Default	Customised value
DHW control	Boiler = DHW (Domestic hot water) control managed from boiler panel			
	Remote = DHW (Domestic hot water) control managed by CAR v2			
Temperature	Temperature read by the DHW probe			
Boost function (*)	Sets the DHW (Domestic hot water) boost function management:			
	Boost: Off = always off		Off-On-Auto	Off
	ON = always on			
	Auto = managed as required by the DHW (Domestic hot water) program			
Set management (*)	Sets the DHW (Domestic hot water) set control mode:			
	Auto = the DHW (Domestic hot water) set will be controlled at two levels, according to the DHW (Domestic hot water) program.		Auto-Man	Man
	Manual = the DHW (Domestic hot water) set will always be fixed at the manual value (regardless of the DHW (Domestic hot water) program)			
Set comfort	Sets comfort set (comfort set will be active during the active time slots of the DHW (Domestic hot water) program if “Set management = Auto” is selected)	10 ÷ 60°C	50°C	
Set economy	Sets reduced set (economy set will be active during the NON active time slots of the DHW (Domestic hot water) program if “Set management = Auto” is selected)	10 ÷ 60°C	30°C	
Set manual	Sets manual set (manual set will be active 24 hours a day if “Set management = Man” is selected)	10 ÷ 60°C	10°C	

(*) See DHW (Domestic hot water) paragraph

Zones Menu.

After accessing as “SERVICE”, the zone menu is enriched with additional parameters with respect to user access.

Press the “Zones” BUTTON to access a list of variables that enable you to customise use of the zones.

Hereunder is a list of available menus:

ZONE	
Menu item	Description
Zone 1	Defines the operating parameters to manage zone 1 (or the entire system if single-zone).
Zone 2 (*)	Defines the operating parameters to manage the zone 2 (if present).
Zone 3 (*)	Defines the operating parameters to manage the zone 3 (if present).

(*) if present.

 The following tables will appear the same also for any Zone 2 and Zone 3.

ZONES/Zone 1	
Menu item	Description
Information	This displays the system operating data
Settings	Defines the operating parameters to manage zone 1
Definition	Defines any further operating parameters to manage zone 1

ZONES/Zone 1/Information		
Menu item	Description	Range
Room temperature (***)	Room temperature read on zone 1	0°C ÷ 50°C
Room Set (**)(***)	Room temperature set on zone 1	5°C ÷ 35°C
Working mode status	Mode set on zone 1	OFF/ A-ECO / A-COMF / MAN
Room thermostat status	Status of the room thermostat on zone 1	Open / Close
Set CH	This displays the zone 1 flow set	25°C ÷ 85°C
Plant	Information related to the type and presence or absence of a room probe	

 Zone 1 Information Menu is always present regardless of whether or not a CAR^{V2} is connected.

(**) not displayed when the “Req. with room probe” is set to NO

(***) displayed when the zone of interest is associated with a room probe (RF probe,...)

ZONES/Zone 1/Information/Plant		
Menu item	Description	Range
Room probe	This displays or not the presence of the room probe	OFF = No probe
		WIRED = Not used
		RF = Probe present
		OT = CARV2 presence
Water circuit	If zone board is present, it informs about the type of system in use in the zone.	DIR = Direct circuit
		MIX = Mixed circuit
CH temperature	Zone board absent: the temperature read is the one to the boiler outlet	0°C ÷ 99°C
	Zones control unit present + request for information relating to the mixed zone	

ZONES/Zone 1/Settings				
Menu item	Description	Range	Default	Customised value
Function Mode (1)	Sets the zone 1 operating mode	OFF / MAN / AUTO	MAN	
Set AUTO Comfort (2)	Zone 1 room temperature correlated to the active time slots of the zone 1 calendar	10°C ÷ 35°C	20°C	
Set AUTO reduced (2)	Zone 1 room temperature correlated to the NON active time slots of the zone 1 program	5°C ÷ 30°C	16°C	
Set MAN (3)	Zone 1 room temperature that can be activated by selecting the operating mode = manual	5°C ÷ 35°C	20°C	
Weather comp. offset (4)	Zone 1 flow temperature correction in relation to external probe detection	-9°C ÷ 9°C	0°C	
Maximum heating set (5)	Maximum zone 1 flow temperature	20°C ÷ 85°C	85°C	

(1) **Not displayed** if remote device present

(2) **Not displayed** when:

- the “Operating mode” parameter is set to “Man” or “Off”;
- lack or unavailability of room and wireless probes;

(3) **Not displayed** when:

- the “Operating mode” parameter is set to “Auto” or “Off”;
- lack or unavailability of room and wireless probes;

(4) **Not displayed** when:

- the external probe is absent/unavailable
- a room probe is configured
- the “Operating mode” parameter is set to “Off”
- the remote device is present

(5) **Not displayed** when:

- the external probe is present
- a room probe is configured
- the “Operating mode” parameter is set to “Off”

ZONES/Zone 1/Definition/Regulation				
Menu item	Description	Range	Default	Customised value
Enable room sensor	With room probe associated, its control can be disabled (No) or enabled again (Yes)	No - Yes	Yes	
Room sensor modul.	With the room probe associated, it is possible to disable the modulation on the flow temperature (No) or enable it again (Yes)	No - Yes	Yes	
Outdoor sensor modul	With the external probe present, it is possible to disable the modulation on the outdoor temperature (No) or enable it again (Yes) for the selected zone	No - Yes	Yes	
Weather comp. offset	With external probe present, the offset value can be set with respect to the climatic curve.	-9°C ÷ 9°C	0°C	
Reduced	Without any association with room probes, it is possible to set a zone flow temperature reduction during the “reduced” bands of the central heating / C.H. calendars	Off ÷ 40°C	Off	
Backlash off temp.	With room probe associated, and “Modul. with room probe” function = The hysteresis cannot be set on the room On-Off control	0,1°C ÷ 1°C	0,2°C	
System inertia	It sets the system reaction speed based on the type of system present; for example: -5: fan-coil system. -10: Radiator system. -20: floor system	1 ÷ 20	10	
External temperat. max	Defines the maximum outdoor temperature at which to operate the central heating system with minimum flow	-5°C ÷ 45°C	25°C	
External temperat. min	Defines the minimum outdoor temperature at which to operate the central heating system with maximum flow	-25°C ÷ 15°C	-5°C	
Maximum flow set	Defines the maximum flow temperature of central heating / C.H. system operation	20°C ÷ 85°C	85°C	
Minimum flow set	Defines the minimum central heating / C.H. system operation flow temperature (if external probe is present, it will be correlated to the maximum outdoor temperature)	20°C ÷ 85°C	20°C	

ZONES/Zone 1/Definition/NoFrost function				
Menu item	Description	Range	Default	Customised value
NoFrost enable	If the wireless room probe is installed, it is possible to activate or not the room antifreeze function when the Zone operating mode is "Off"	No - Yes	Yes	
NoFrost temperature	If wireless room probe is installed and the antifreeze function is enabled, it is possible to define the room antifreeze trigger temperature	-5°C ÷ 10°C	5°C	

ZONES/Zone 1/Definition/Room probe				
Menu item	Description	Range	Default	Customised value
Type	Makes it possible to select the type of probe to be associated with the zone in question	OFF = No probe	Off	
		WIRED = Not used		
		RF = Configuration to activate association with a wireless room probe		
Address M3	During the association, it is necessary to enter the concentrator acknowledgement address (see dip-switch on concentrator)	0 ÷ 2		
Status	This displays the association status with wireless probe	ERR = Association procedure failed		
		No-link = Probe cannot be reached via RF		
		... (in config) = Probe association in progress		
		OK = Probe correctly associated		

Main Menu.

Press the "MENU" button to access a list of variables that enable you to customise use of the system.

Below is a list of the menus available after accessing as Service:

MENU	
Menu item	Description
Time and program	Defines the date/time and time operating slots
Information	Display system operating data
Historical alarm code	Displays the list of the last 10 anomalies
Counters	This displays the number of ignitions and the hours of operation of the burner
General settings	Allows selecting the panel operating language, the display operating mode and to access the password-protected menus dedicated to a qualified technician.
Service	Gives access to the functions exclusive for Service

MENU/Time and program				
Menu item	Description	Range	Default	Customised value
Date and time	Current date and time setting			
Auto switch to DST	Automatically sets summer time	Yes - No	Yes	
Calendars	Defines the time range for operation in Comfort and Economy mode			
Zone 1 program	Zone 1 time scheduling		CAL3	
Zone 2 program	Zone 2 time scheduling (if present)		CAL3	
Zone 3 program	Zone 3 time scheduling (if present)		CAL3	
DHW Program	DHW operation time programming		CAL3	
Holiday program	Defines the period during which the system disables both hot water heating and room central heating functions. At the end of the set days, the previously active functions will be reset.	Off - 1 ÷ 30 gg	Off	

MENU/Information	
Menu item	Description
Gas type	Gas type display: NG (Methane), LG (L.P.G.), AP (propane air)
Flame signal	Flame signal display
CH temperature	Flow temperature display
DHW temperature	Storage tank/DHW (Domestic hot water) outlet temperature display
Set CH	This displays the set central heating / C.H. temperature set
Set DHW	Set DHW (Domestic hot water) temperature display
External temperature	(Optional)
Input DHW temperature	Not used on this model
CH Return temperature	Return temperature display
CH2 temperature	Safety flow probe display
Common flow probe	(Optional)
Duty pump command	Control signal of the pump duty PWM
Flow pump	System flow rate display
Flow rate	Not used on this model
Fan speed	Fan speed display (rpm)
Boiler exhaust temp.	Flue gas temperature display
Solar storage temp.	Not used on this model
Solar collector temp.	Not used on this model
Maintenance withing	This displays the number of days within which maintenance must be carried out. After the days or with the function deactivated, the line is not displayed
Main board rev. SW	Boiler board sw version display
Firmware version	Display board sw version display

MENU/Historical alarm code	
Menu item	Description
Show alarm	This displays the boiler anomaly history. The size of the anomaly history is equal to 10 anomalies.
Alarm reset	Resets the list of anomalies

MENU/Counters	
Menu item	Description
Burner ignitions number	Number of burner ignitions counter
Burner working hours	Burner operating hours meter

MENU/General settings				
Menu item	Description	Range	Default	Customised value
Language	Defines the remote panel operation language		ITA (*)	
Display	It is possible to adjust the contrast and lighting of the display. The lighting (available on two levels) can be automatically selected as fixed or variable during the boiler operation or user access to the display			
Menu access level	Allows the entry of an access code to access the parameter customisation menus according to one's needs (dedicated to a qualified technician)			
User factory settings	Resets the user parameters to default state			
Service factory settings	Resets the service parameters to default state: the boiler parameters are excluded (hydraulic and combustion setting)			

(*) The display leaves the factory set in Italian. To change the display language, see Par. 2.5 in the "USER" chapter, under "Changing the display language".

In case the user restores the factory conditions through "Menu/General settings/User factory settings", the menu will appear in English. Proceed in the following way to restore the desired display language:

- Enter **Menu/General setting/Language**.
- Select the desired language from those available and press OK.

Assistance menu access

MENU/General settings/Menu access level

To activate the access reserved to Service, follow the above path; upon "Access code request", enter code 1122 (using the "DHW (Domestic hot water) set" and "Central heating / C.H. set" knobs) and press "OK", then the "Access level" menu will open where it is possible to select the "Service" access type. The authentication as Service gives access to the parameters reserved for a qualified Technician.

MENU/Service	
	Boiler
	Domestic Hot Water
	Central Heating
	Inputs
	Dominus
	Special function
	Maintenance

MENU/Service/Boiler/Hydraulic				
Menu item	Description	Range	Default	Customised value
Hydraulic	Defines the type of boiler hydraulics	Istan. = not used on this model	Bol. : with hot water production in accumulation	
		Bol. = with hot water production in accumulation		
		Herc. = not used on this model		
		Herc. Sol. = not used on this model		

MENU/Service/Boiler/Combustion				
Menu item	Description	Range	Default	Customised value
Model	Set the heat generator type	1 ÷ 30	Victrix Zeus Superior 25 = 5 Victrix Zeus Superior 30 = 4 Victrix Zeus Superior 35 = 3	
Gas type	Defines the type of gas:	NG = operation with Methane gas	NG = Methane	
		LG = operation with LPG gas		
		AP = operation with Propane Air gas		
Fan rpm min	Setting of minimum fan speed (absolute)	450 - 3500 (rpm)	Victrix Zeus Superior 25 = 2150 rpm Victrix Zeus Superior 30 = 2350 rpm Victrix Zeus Superior 35 = 2350 rpm	
Fan rpm max	Setting of maximum fan speed (absolute)	3500 ÷ 8300 (rpm)	Victrix Zeus Superior 25 = 6400 rpm Victrix Zeus Superior 30 = 6950 rpm Victrix Zeus Superior 35 = 6950 rpm	
Fan rpm ign.	Sets burner ignition fan speed	2000 ÷ 4500 (rpm)	Victrix Zeus Superior 25 = 3800 rpm Victrix Zeus Superior 30 = 3500 rpm Victrix Zeus Superior 35 = 3500 rpm	
Maximum calibr. range	Activates a greater combustion set adjustment range during complete calibration	No = normal combustion set adjustment range	No	
		Yes = extended combustion set adjustment range		



A change in values of this table will cause a boiler block with E62 appearing and consequent request for complete calibration.



The P.C.B. defines the operating mode and the boiler output according to the combination of several parameters. The correct fan revolutions to obtain the correct operating power of the appliance are defined from the combination of parameters "Model", "Gas type", "Flue Length"; this is why it is suggested not to modify the "Fan rpm" parameters.

MENU/Service/Boiler/Powers				
Menu item	Description	Range	Default	Customised value
Power max DHW	Defines the maximum heat output percentage of the boiler during the D.H.W. phase compared to the maximum heat output available	0 ÷ 100 (%)	Victrix Zeus Superior 25 = 100 Victrix Zeus Superior 30 = 83 Victrix Zeus Superior 35 = 100	
Power min DHW	Defines the minimum heat output percentage of the boiler during the D.H.W. phase compared to the minimum heat output available	0 ÷ 100 (%)	Victrix Zeus Superior 25 = 22 Victrix Zeus Superior 30 = 17 Victrix Zeus Superior 35 = 17	
Power max CH	Defines the maximum heat output percentage of the boiler during the central heating mode compared to the maximum heat output available	0 ÷ 100 (%)	Victrix Zeus Superior 25 = 73 Victrix Zeus Superior 30 = 75 Victrix Zeus Superior 35 = 75	
Power min CH	Defines the minimum heat output percentage of the boiler during the central heating mode compared to the minimum heat output available	0 ÷ 100 (%)	Victrix Zeus Superior 25 = 0 Victrix Zeus Superior 30 = 0 Victrix Zeus Superior 35 = 0	
Correction flow DHW	Not used on this model	-9 ÷ 9 (kw)	0	



The P.C.B. defines the operating mode and the boiler output according to the combination of several parameters. The correct ranges to obtain the correct operating power of the appliance are defined from the combination of parameters "Model", "Gastype", "FlueLength".

MENU/Service/Boiler/External relays				
Menu item	Description	Range	Default	Customised value
Relay 1	The boiler is set-up for functioning with the relay board (optional), which can be configured on relay 1	Off = relay always Off	Zone 1	
		Zone 1 = Zone 1 control		
		Allarm = =General alarm		
		CH active = Central heating mode / C.H. mode active		
		Gas valve = External gas valve power supply		
		Three-wa = Active together with three-way position in central heating / C.H.		
		DHW active = Central heating mode / C.H. mode active		
Relay 2	The boiler is set-up for functioning with the relay board (optional), which can be configured on relay 2	Off = relay always Off	Off	
		Allarm = =General alarm		
		CH active = Central heating mode / C.H. mode active		
		Gas valve = External gas valve power supply		
		Zone 2 = Zone 2 control		
		PdC = not used on this model		
		DHW active = Domestic hot water mode / DHW mode active		
Relay 3	The boiler is set-up for functioning with the relay board (optional), which can be configured on relay 3	Off = relay always Off	Off	
		CHL active = not used on this model		
		Allarm = =General alarm		
		CH active = Central heating mode / C.H. mode active		
		Gas valve = External gas valve power supply		
		PdC = not used on this model		
		*Storage tank recirc. = Storage tank recirculation pump active when Boost is active		
		Zone 1 = Zone 1 control		
		DHW active = Domestic hot water mode / DHW mode active		

(*) To activate recirculation using the "recirculation pump" optional kit, in addition to configuring the relay, it is necessary to activate the Boost function. With Boost On, recirculation is always running. With Boost Auto, recirculation works according to the time slots set on the DHW (Domestic hot water) program (on in comfort and off in economy).

INSTALLER

USER

MAINTENANCE TECHNICIAN

TECHNICAL DATA

MENU/Service/Boiler/Flue				
Menu item	Description	Range	Default	Customised value
Length	Sets flue length	min / med / max	Min	
Enable klapet valve	Not used on this model	Complete / Partial	Complete	



A change in these parameters will cause the boiler block signalled with E72; to reset E72, a quick calibration must be activated.

MENU/Service/Boiler/Timers				
Menu item	Description	Range	Default	Customised value
Antiheating cycles	Central heating / C.H. anti-cycle timer set	0 ÷ 840	180 seconds	
Heating ramp	Set central heating ramp timer	0 ÷ 840	180 seconds	
RT request delay	Set delay timer requested by TA	0 ÷ 600	0 seconds	
Solar delay	Not used on this model	0 ÷ 300	0 seconds	
Waiting time priority	Not used on this model	0 ÷ 100	0 seconds	
Antilegionella stop	Sets anti-legionella end temp	0 ÷ 255	180 minutes	
Boiler end of precedence	Not used on this model			

MENU/Service/Boiler/Circulator				
Menu item	Description	Range	Default	Customised value
Mode	Sets the central heating / C.H. pump operation mode	Interm. = in winter "mode" the pump is managed according to the room control request.	Interm.	
		Cont. = in "Winter" mode the pump is always powered and is therefore always in operation		
Max speed	Sets the maximum pump operating speed in central heating / C.H.	1 ÷ 9	9	
Min speed	Sets the minimum pump operating speed in central heating / C.H.	1 ÷ 9	6	
Delta t	This defines the type of speed control of the pump in central heating / C.H.	Delta t = 0: head proportional to the power supplied by the burner	15°C	
		Delta t = 5...25: constant Delta t operation (at the set value)		

MENU/Service/Domestic Hot Water

Menu item	Description	Range	Default	Customised value
Boiler control input	Set the type of board input on which to activate the storage tank control	ntc: storage tank control performed via NTC probe	ntc:	
		dig: storage tank control performed via contact (not used on this model)		
		ntc+dig: storage tank control performed by summing the probe reading and the enabling contact (not used on this model)		
DHW hysteresis	Set the storage tank control hysteresis and temperature	hyster. 0: 3k control hysteresis and flow = set +25k	hyster. 1	
		hyster. 1: 3k control hysteresis and flow correlated to boiler power		
		hyster. 2: 10k control hysteresis and flow correlated to set		
		hyster. 3: 5k control hysteresis and flow fixed at 85°C		
		hyster. 4: hysteresis and flow settable on parameters below the item		
Boil.water temp. hyst. 4	Set the storage tank flow temperature for hysteresis type 4	35 ÷ 85	70°C	
Diff. prec. with hyst. 4	Set the storage tank control hysteresis for type 4 hysteresis	2 ÷ 10	6°C	
DHW flow regulator	Not used on this model	Open / 8l/min / 10l/min / 12l/min / 14l/min / 16l/min / Auto / Auto H / Auto T / Auto HT	Open [0]	
DHW min set	Set minimum DHW (Domestic hot water) set limit available to user	10 ÷ 65	10°C	
DHW max set	Set maximum DHW (Domestic hot water) set limit available to user	10 ÷ 65	60°C	
Antilegionella	Anti-legion.cycle time: Sets the anti-legionella function intervention time	00:00 ÷ 24:00	02:00	
	Anti-legion.cycle day: Sets the day(s) of activation of the anti-legionella function	None ... All	None	

MENU/Service/Central Heating

Menu item	Description	Range	Default	Customised value
CH min set	Set minimum central heating / C.H. set limit available	20 ÷ 85	20°C	
CH max set	Set maximum central heating / C.H. set limit available	20 ÷ 85	85°C	
Edit external probe	Sets correction factor on external probe reading	-9 ÷ 9	0°C	
Edit max common flow probe	Sets the maximum limit for boiler flow set correction from system flow probe reading (Optional)	0 ÷ 15	5°C	

INSTALLER

USER

MAINTENANCE TECHNICIAN

TECHNICAL DATA

MENU/Service/Inputs				
Menu item	Description	Range	Default	Customised value
Configurable input	Sets the management of the input available at connection terminals 38 and 20	Disable/Flow temp./Photovol.	Disable	
Remote control	Sets the dialogue protocol with remote device	IMG - 1 - 2 - 3	IMG	

MENU/Service/Dominus				
Menu item	Description	Range	Default	Customised value
Enable	Enables dialogue in Dominus app	No - Yes	No	

MENU/Service/Special function/Deaeration				
Menu item	Description	Range	Default	Customised value
Enable vent	Vent enabled: to activate automatic venting at each power-on	No - Yes	No	
Deaeration comand	Activates/deactivates the deaeration control with a command	Stop - Start		
Function duration in hours	This displays the time remaining until the end of the function	0 - 255 (h)		
Fault	This displays any current anomaly	--		

MENU/Service/Special function/Chimney sweeper				
Menu item	Description	Range	Default	
En. chimney sweeper	Chimney sweep function active	Stop - Start	Stop	
Status	Notifies the function status	Off - On		
Set power level	Set power level	0 ÷ 100%		
Fan speed	Fan speed display (rpm)	-- (rpm)		
CH temperature	Flow temperature display	0 ÷ 99°C		
Flame	This displays the flame status	Off - On		
Circuit CH	Notification if central heating / C.H. is activated	Off - On		
Circuit DHW	Notification if DHW (Domestic hot water) is activated	Off - On		
Fault	This displays any current anomaly	--		

MENU/Service/Special function/Test flue				
Menu item	Description	Range	Default	
En. test flue	Activate the flue test function	Stop - Start	Stop	
Status	Notifies the function status	Off - On		
Fan speed	Fan speed display (rpm)	-- (rpm)		
Fault	This displays any current anomaly	--		

MENU/Service/Special function/Complete calibration

Menu item	Description	Range
Complete calibration	Activates the complete calibration function (Access to the calibration window with activation of the complete calibration command: makes it possible to change the combustion set)	

MENU/Service/Special function/Fast calibration

Menu item	Description	Range
Fast calibration	Activates the quick calibration function (Access to the calibration window with activation of the quick calibration command)	

INSTALLER**USER****MAINTENANCE/TECHNICIAN****TECHNICAL DATA**

MENU/Service/Special function/Screed heater				
Menu item	Description	Range	Default	Customised value
En. screed heater	Activates the function with Yes selected and the advanced end if No is selected	No - Yes	No	
Minimum flow set	It is possible to set the minimum flow temperature at screed heater function start	20 ÷ 45 (°C)	25°C	
Maximum flow set	It is possible to set the maximum flow temperature delivered during the screed heater function	25 ÷ 55 (°C)	45°C	
Time spent set min	It is possible to set the days of stay at minimum flow set during the screed heater function	1 - 7 (days)	3 gg	
Climb gradient	It is possible to set the ascent variation speed from minimum flow set to maximum flow set during the screed heater function	3 - 30 (°C/day)	30°C/g	
Time spent set max	It is possible to set the days of stay at maximum flow set during the screed heater function	1 - 10 (days)	4 gg	
Descent gradient	It is possible to set the descent variation speed from maximum flow set to minimum flow set during the screed heater function	3 - 30 (°C/day)	30°C/g	
Status	This displays the screed heater function progress	Off = deactive function		
		Min = function active with stay time at minimum flow set		
		Up = function active with increase from minimum flow set to maximum flow set		
		Max = function active with stay time at maximum flow set		
		Down = function active with decrease from maximum flow set to minimum flow set		
Holding time T max	T is displays the stay time at maximum screed heater temperature (h)	(h)		
Function duration in days	This displays the time remaining until the end of the function in days	(days)		
Function duration in hours	This displays the time remaining in hours until the end of the function (to be added to the days of the previous item)	(h)		

MENU/Service/Maintenance				
Menu item	Description	Range	Default	Customised value
Select number of months	Sets the number of months for scheduled maintenance	Off - 36	Off	

3.16 SPECIFIC INFORMATION FOR CORRECT BOILER INSTALLATION IN COMMON PRESSURISED FLUE SYSTEMS (C10 - C12)



The boiler is factory equipped with a flue gas non-return valve located downstream of the fan, this device, given the importance of its correct operation, must have its installations C(10) and C(12) checked on an annual basis, and the active rubber element must be replaced in case of cuts in the moving parts.



For safety reasons, the flue gas non-return valve must be replaced after 10 years of operation.

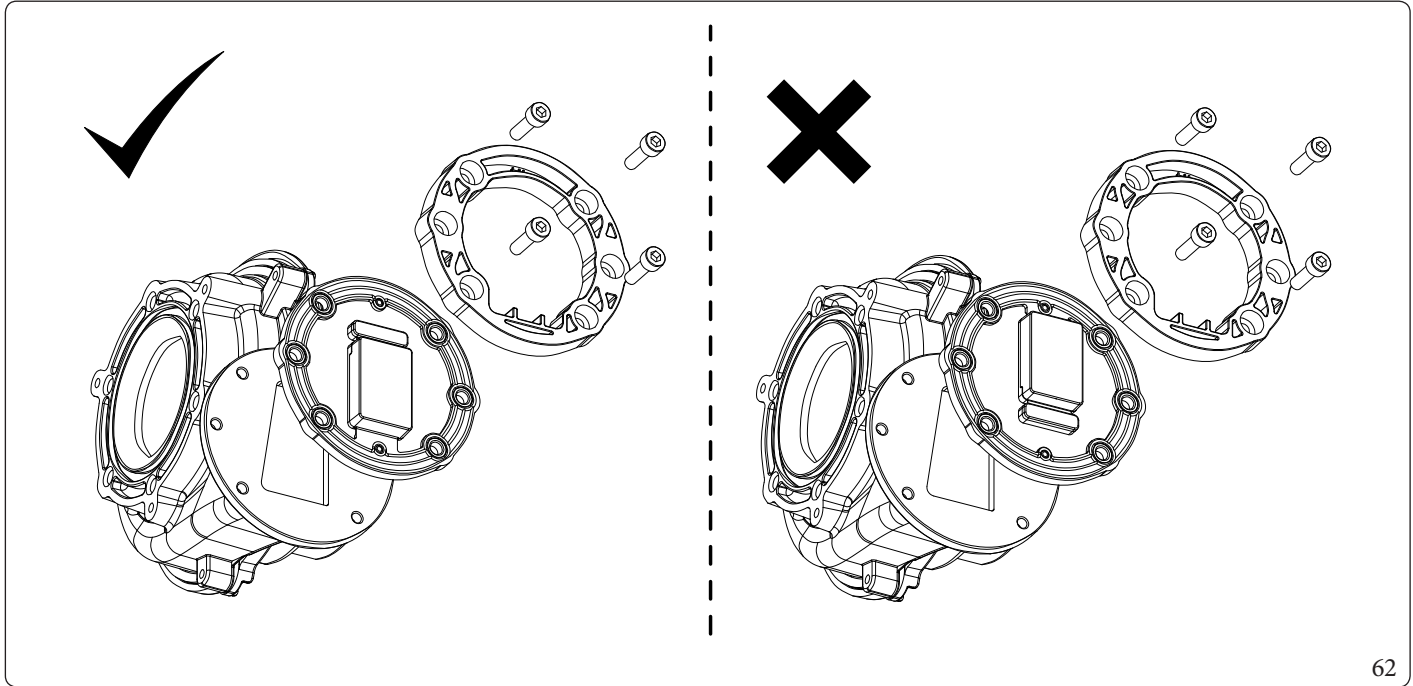

Before removing the sealing elements of the sealed chamber, using the flue gas analyser and with the boiler off, check that there are no traces of combustion products in the flue gas sample point.

The presence of combustion products indicates that the non-return valve on the flue gas (in boiler exhaust) is not properly closed, in which case it is appropriate to check the absence of flue gas even in the sealed chamber (analysis via air sample point).



If malfunctions are detected on the flue gas non-return valves, especially on the discharge valve, in the absence of a shut-off flue adjusting device at the coupling point of the flue in the pressurised collective flue, it will be necessary to turn off all the boilers connected to the pressurised collective flue itself, or make sure to intercept the connection point to avoid the dispersion of combustion products into the environment.

Only then proceed to verify the components, making sure that the non-return valve siphon on the flue gas (on the exhaust) is full and replacing them if malfunctioning or damaged.

3.17 BOILER COUPLING WITH WIRELESS ROOM PROBES

The kit concentrator with probe consists of two devices capable of communicating together via radio frequency. The radio association between the two devices **is not factory set**.

It is necessary to perform the following operations at the time of installation, in order to activate radio acknowledgement and assign room control to the correct zone.

The room probe will be positioned in the room where temperature control is required.

The room probe works with the use of two 1.5V AA batteries and does not require electrical connection via wires.

The concentrator must be connected to the boiler by wiring (supplied with the kit) and positioned near the boiler.

If necessary it can be placed away from the boiler; in this case, it is necessary to provide a suitable electrical connection (not supplied with the kit).



Both the probe and the concentrator are suitable for indoor operation; they cannot be used outdoors and/or in environments subject to atmospheric agents.

Association procedure:

Insert the batteries on the probe and press the button on the probe for 5 sec.



If the probe is already previously associated, the LH and RH LEDs will flash alternately, therefore **it is necessary to proceed with the RF disassociation** (see RF Disassociation operations); if it is **not associated** the LH LED will start to flash (RH LED off), then continue with the next step of this procedure.

Zone assignment to wireless room probe:

1. make sure to have correctly made the electrical connections between concentrator and boiler and to have inserted the batteries on the wireless probe;
2. feed the boiler and access the Menu. For more details on menu navigation and access controls, see (Par. 2.6);
3. access with the "Service" credentials;
4. access the Zones Menu;
5. select the zone to which the room probe refers;
6. enter the Definition/Room probe menu;
7. Select Type = RF;
8. set the M3 address of the concentrator to which to associate the wireless probe (the M3 address is defined by the position of the switches on the board inside the concentrator, default 0);
9. press OK (a confirmation window will be displayed with the text "Confirm operation?");
10. accept the confirmation request by pressing OK; then the display will show "Status ..." (association in progress) and Lh LED will flash on the concentrator (pending association);
11. move to the probe to be associated within 30 seconds and press the central button for 5 seconds. When the LH LED flashes, briefly press the button again (1 second);
12. once the operation has been completed correctly, the 2 LH and RH LEDs will flash alternately on the probe for 10 sec. to then indicate on the LH LED the number of the associated zone by flashing, with the RH LED steady. If the operation is not completed correctly, the two LEDs will flash synchronously for 5 seconds and the display will show the text "Status No-Link" (the operation needs to be repeated);
13. on Display, when the operation is completed correctly, the room probe status appears as "OK".

Indications displayed on the "Room probe - Status" menu

The following items appear in the Room probe association window:

- **Status = Err:** configuration error; the association sequence on the concentrator was not successful. Repeat the association sequence.
- **Status = No link:** error on RF association between probe and concentrator; it may also appear with probe battery flat. Check wireless probe operation and repeat the association sequence.
- **Status = - - :** indicates the wait for configuration; if it is maintained for a long time during the association sequence, check the connection between the concentrator and boiler.
- **Status = ... :** indicates the mode of association in progress.
- **Status = ok:** indicates the correct association between the wireless probe and the zone to be controlled.

RF disassociation on wireless room probe

Should it be necessary to reset a previous assignment made on the room probe, proceed with the following operation on the room probe:

1. Press and hold the RF Probe button for at least 5s, if it is associated the LH-LEDs and the RH-LEDs will start to flash alternately;
2. At this point, press the button again for 5s and release it when only the LH-LED starts flashing while the RH-LED remains off;
3. Wait until the LH LED stops flashing before making a new association.

By using optional kits such as the concentrator kit for wireless room probes (if necessary to manage a single zone) and any wireless room probe kit (to manage any other zones up to a maximum of 3), it is possible to activate a room control in central heating / C.H. managed directly by the boiler.

The central heating / C.H. program will manage two room temperatures (comfort and reduced) in combination with the slots requested on the central heating / C.H. program (possibly diversified for the 3 zones).

Under these conditions, it will be possible to activate a system flow temperature modulating control so as to limit consumptions (enter any temperature control class, see table below).

To complete the room control via wireless probes, it is possible to connect the external probe (optional) and activate the control via the Dominus App (optional).

Remember that the central heating / C.H. demand, in addition to being subject to the central heating / C.H. program and to the temperature detected by the room probe, it will also be controlled by the contact set up for limit switch micro (terminals 40-41 for single zone).

For the electrical connection, configuration and correct management of the room probes (+ concentrator), see the kit instruction sheet.

Class	Contribution to room central heating seasonal energy efficiency	Description
I	1%	Using up to 2 Wireless room probes with modulating function excluded
V	3%	Using up to 2 Wireless room probes with modulating function active
VI	4%	Using up to 2 Wireless room probes with modulating function active on room and on external temperature (+ external probe connected to boiler)
VIII	5%	Using 3 Wireless room probes with modulating function active

3.18 AUTOMATIC VENTING FUNCTION

The De-aeration setting and activation control is available in the Menu (with Service recognition) at the following path:

Menu/Service/Special function/Deaeration

Once in the "Deaeration", page, the window allows the first line to activate automatic de-aeration each time the appliance is powered by selecting "Enable vent = Yes" (standard setting).

This function lasts 8 minutes and it can be ended both by setting "Enable vent = No" and by pressing the "RESET" buttons on the control panel.

On the second line of the "Deaeration" page it is possible to activate the manual de-aeration by selecting "Deaeration comand = Start".

This function lasts 18 hours and it can be ended both by setting "Deaeration comand = Stop" and by pressing the "RESET" buttons on the control panel.

3.19 "CHIMNEY SWEEP" FUNCTION

When activated, this function forces the boiler to variable output for 15 minutes.

In this state, all adjustments are excluded and the safety thermostat and the limit thermostat functions remain active. To activate the chimney sweep function, it is necessary to go to the following path:

Menu/Service/Special function/Chimney sweeper

Activate the function in the first line by selecting "Start".

This function makes it possible for the technician to check the combustion parameters in the working range that goes from minimum central heating / C.H. Q. to Nominal central heating / C.H. Q.

It is possible to select whether to make the chick in CH status or DHW status by opening any hot water cock.

The power supplied by the burner can be adjusted within the chimney sweep menu on the "Set power level" parameter.

The central heating or D.H.W. operating mode is displayed on the chimney sweep window.

After completing the checks, disable the function by selecting "Stop".

3.20 SCREED HEATER FUNCTION

The boiler is equipped with a function to perform the thermal shock on new radiant panel systems, as required by the applicable standard.

The function can only be activated when the boiler is in antifreeze mode.



Contact the manufacturer of the radiant panels for the thermal shock characteristics and its correct execution.



To be able to activate the function there must be no remote control connected, while in case of system divided into zones it must be properly connected, both hydraulically and electrically.

Menu/Service/Special function/Screed heater

The active zone pumps are those with ongoing requests, made via the room thermostat input.

The standard function lasts in total 8 days - 3 days at the lowest temperature set and 5 days at the highest temperature selected plus the time necessary for the ascent and descent variations (Fig. 63).

Duration can be changed by changing the value of parameters, see (Par. 2.6).

At this point, the message “Screed heater in progress” appears on the display.

In case of failure, the function is suspended and will resume when normal operating conditions are reset from the point where it was interrupted.

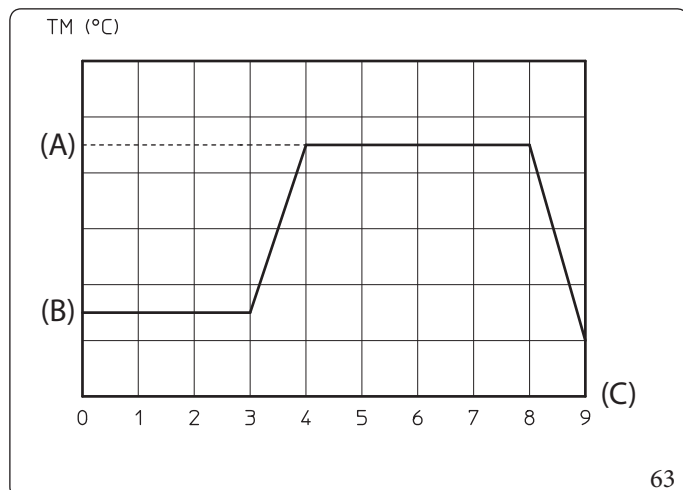

3.21 PUMP ANTI-BLOCKFUNCTION

The boiler has a function that starts the pump at least once every 24 hours for the duration of 30 seconds in order to reduce the risk of the pump becoming blocked due to prolonged inactivity.

3.22 THREE-WAY ANTI-BLOCKSYSTEM

Both in “domestic hot water” and in “domestic hot water-central heating” phase the boiler is equipped with a function that starts the three-way motorised group 24 hours after it was last in operation, running it for a full cycle so as to reduce the risk of the three-way group becoming blocked due to prolonged inactivity.

3.23 RADIATORS ANTIFREEZE FUNCTION

If the system return water is below 4°C, the boiler starts up until reaching 42°C.

3.24 P.C.B. PERIODICAL SELF-CHECK

During functioning in central heating mode or with boiler in standby, the function activates every 18 hours after the last boiler check/power supply. In case of functioning in domestic hot water mode the self-check starts within 10 minutes after the end of the withdrawing in progress, for duration of approx. 10 seconds.



During the self-check the boiler remains inactive. Notifications included.

3.25 CASINGREMOVAL

To facilitate boiler maintenance the casing can be completely removed as follows:

Lower grid (Fig. 64)

1. Loosen the two screws (a).
2. Remove the grid (b).

Front panel (Fig. 65)

3. Remove the cover caps (c) and loosen screws (d).
4. Loosen the two screws (e) secured under the hinges.
5. Pull the front panel (f) towards you and release it from its lower seat.

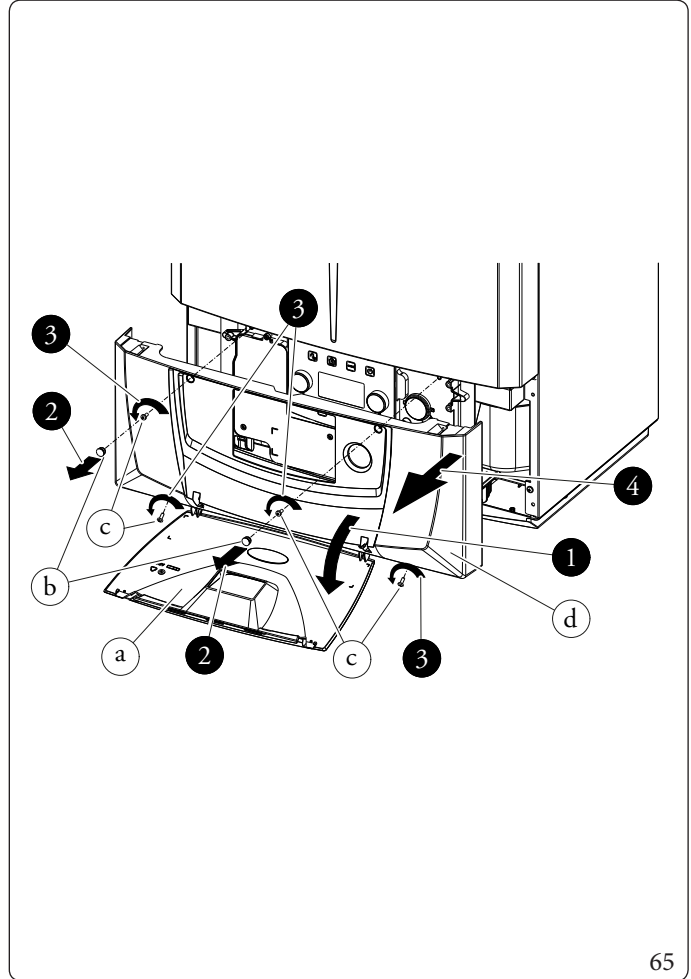
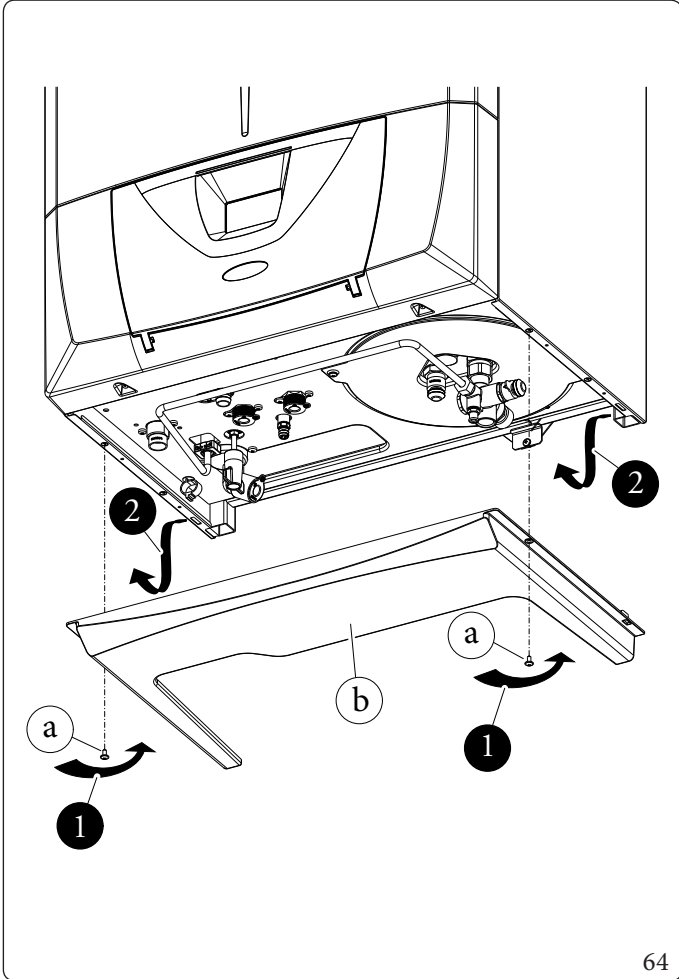

Front (Fig. 66)

6. Loosen the two screws (g).
7. Pull the front (f) slightly towards you.
8. Release the front (f) from the bracket (h) by pushing upwards and towards you.

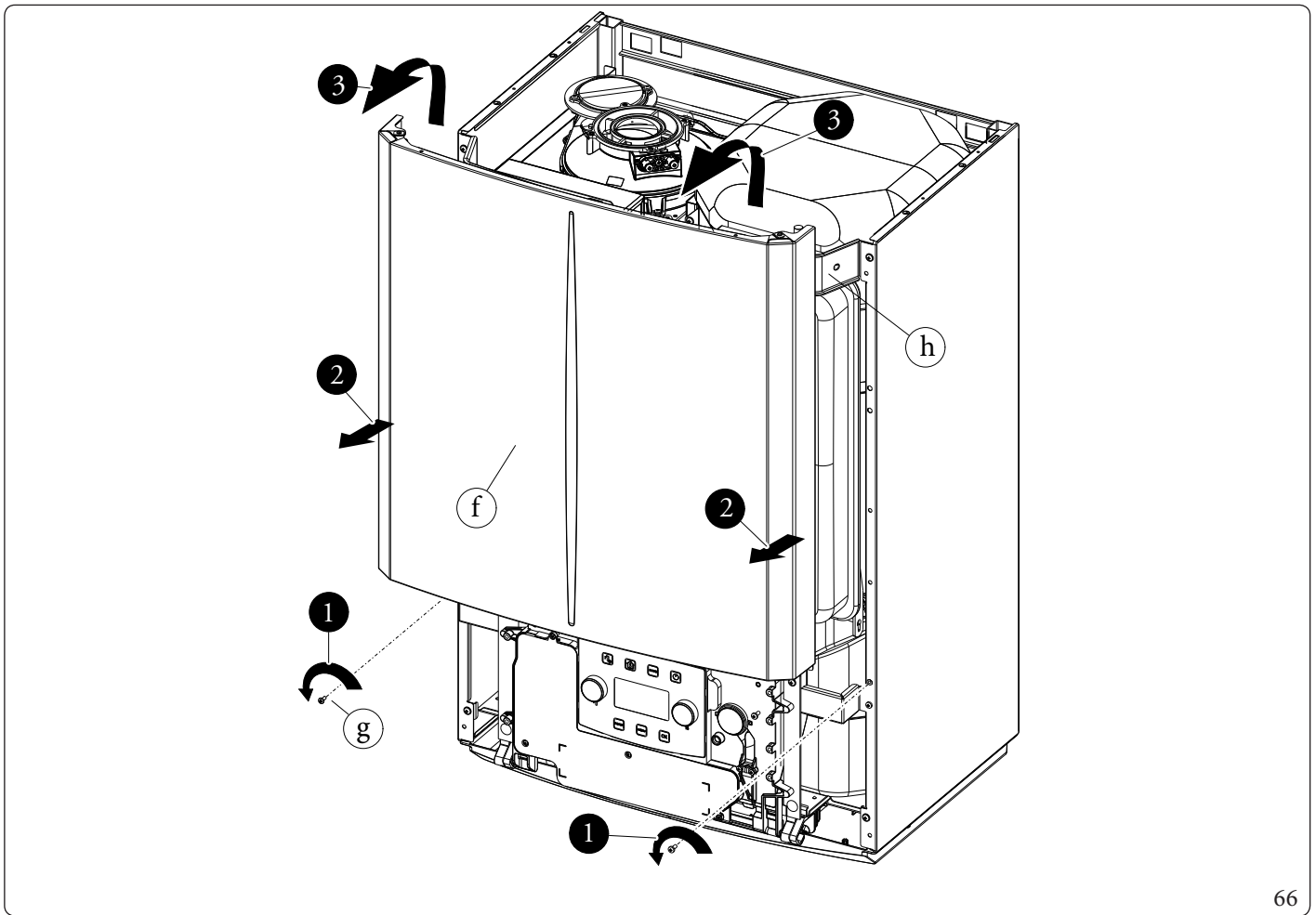

Control panel (Fig. 67)

9. Loosen the fixing screws (i) from the front panel.
10. Tilt the control panel (j) towards you.

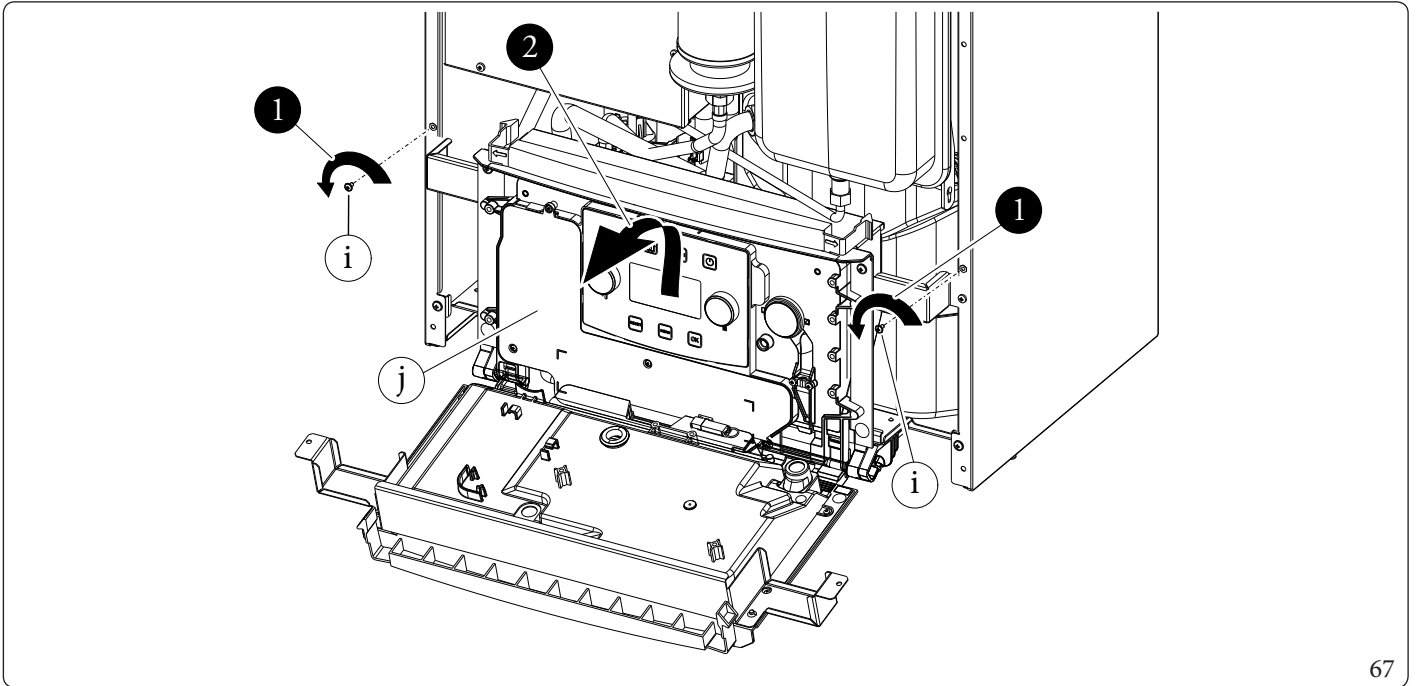

67

Sides (Fig. 68)

11. Unscrew the side (k) fastening screws (l).
12. Remove the sides by extracting them from their rear seat (Ref. X).

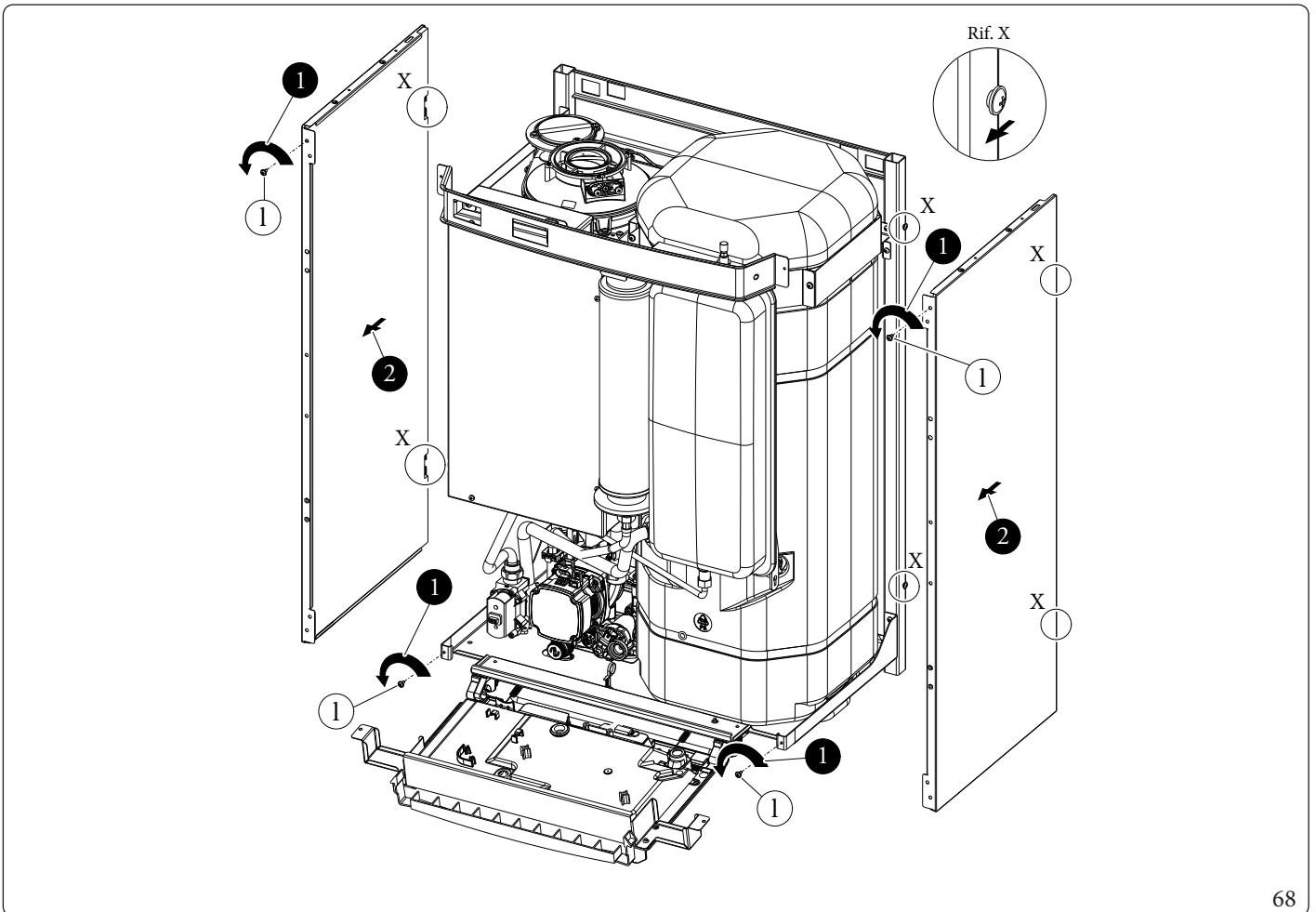

68

INSTALLER

USER

MAINTENANCE/TECHNICIAN

TECHNICAL DATA

4 TECHNICAL DATA

4.1 VARIABLE HEAT OUTPUT



The power data in the table has been obtained with intake-exhaust pipe measuring 0.5 m in length. Gas flow rates refer to net calorific value below a temperature of 15°C and at a pressure of 1013 mbar.

Victrix Zeus Superior 25

HEAT OUTPUT	HEAT OUTPUT		METHANE (G20)		PROPANE (G31)	
			MODULATION	GAS FLOW RATE BURNER	MODULATION	GAS FLOW RATE BURNER
(kW)	(kcal/h)		(%)	(m ³ /h)	(%)	(kg/h)
25,0	21500	D.H.W.	99	2,74	99	2,01
24,0	20640		93	2,63	92	1,93
23,0	19780		86	2,52	85	1,85
22,0	18920		81	2,41	79	1,77
21,0	18060		76	2,29	74	1,68
20,2	17372		73	2,20	70	1,62
19,0	16340	HEAT. + D.H.W.	69	2,07	62	1,52
18,0	15480		64	1,96	59	1,44
17,0	14620		60	1,85	57	1,36
16,0	13760		57	1,74	55	1,28
15,0	12900		53	1,63	53	1,20
14,0	12040		50	1,52	51	1,12
13,0	11180		46	1,41	48	1,04
12,0	10320		44	1,30	44	0,96
11,0	9460		40	1,20	40	0,88
10,0	8600		38	1,09	37	0,80
9,0	7740		34	0,98	34	0,72
8,0	6880		32	0,87	31	0,64
7,0	6020		30	0,77	26	0,56
6,0	5160		27	0,66	23	0,49
5,0	4300	23	0,55	20	0,41	
4,7	4042	22	0,52	18	0,38	
3,0	2580	11	0,34	11	0,25	
2,3	2012	1	0,26	1	0,19	

Victrix Zeus Superior 30

				METHANE (G20)		PROPANE (G31)	
HEAT OUTPUT	HEAT OUTPUT		MODULATION	GAS FLOW RATE BURNER	MODULATION	GAS FLOW RATE BURNER	
(kW)	(kcal/h)		(%)	(m ³ /h)	(%)	(kg/h)	
30,0	25800	D.H.W.	83	3,27	80	2,40	
29,0	24940		79	3,16	76	2,32	
28,2	24252		75	3,07	73	2,26	
27,0	23220		70	2,94	70	2,16	
26,0	22360		65	2,83	65	2,07	
25,0	21500		60	2,71	60	1,99	
24,0	20640		55	2,60	55	1,91	
23,0	19780		50	2,49	50	1,83	
22,0	18920		55	2,38	47	1,74	
21,0	18060		40	2,26	43	1,66	
20,0	17200	HEAT. + D.H.W.	38	2,15	40	1,58	
19,0	16340		36	2,04	38	1,50	
18,0	15480		34	1,93	36	1,42	
17,0	14620		32	1,82	34	1,34	
16,0	13760		30	1,71	32	1,26	
15,0	12900		29	1,61	30	1,18	
14,0	12040		27	1,50	29	1,10	
13,0	11180		26	1,39	28	1,02	
12,0	10320		25	1,29	26	0,94	
11,0	9460		24	1,18	25	0,87	
10,0	8600		22	1,08	23	0,79	
9,0	7740		20	0,97	21	0,71	
8,0	6880		19	0,87	20	0,64	
7,0	6020		17	0,76	13	0,56	
6,0	5160		14	0,66	11	0,48	
5,0	4300		10	0,55	10	0,41	
4,0	3440		5	0,44	7	0,33	
3,0	2580		2	0,34	3	0,25	
2,8	2408	1	0,31	1	0,23		

INSTALLER

USER

MAINTENANCE TECHNICIAN

TECHNICAL DATA

Victrix Zeus Superior 35

INSTALLER

USER

MAINTENANCE TECHNICIAN

TECHNICAL DATA

			METHANE (G20)		PROPANE (G31)	
HEAT OUTPUT	HEAT OUTPUT		MODULATION	GASFLOWRATE BURNER	MODULATION	GASFLOWRATE BURNER
(kW)	(kcal/h)		(%)	(m ³ /h)	(%)	(kg/h)
33,8	29068	D.H.W.	99	3,69	99	2,71
33,0	28380		95	3,60	95	2,64
32,0	27520		90	3,49	90	2,56
31,0	26660		86	3,38	85	2,48
30,0	25800		82	3,27	80	2,40
29,0	24940		78	3,16	76	2,32
28,2	24252		75	3,07	73	2,26
27,0	23220	HEAT. + D.H.W.	70	2,94	70	2,16
26,0	22360		65	2,83	65	2,07
25,0	21500		60	2,71	60	1,99
24,0	20640		55	2,60	55	1,91
23,0	19780		50	2,49	50	1,83
22,0	18920		55	2,37	47	1,74
21,0	18060		40	2,26	43	1,66
20,0	17200		38	2,15	40	1,58
19,0	16340		37	2,04	38	1,50
18,0	15480		34	1,93	36	1,42
17,0	14620		32	1,82	34	1,34
16,0	13760		30	1,71	32	1,26
15,0	12900		29	1,60	30	1,18
14,0	12040		27	1,50	29	1,10
13,0	11180		26	1,39	28	1,02
12,0	10320		25	1,29	26	0,94
11,0	9460		24	1,18	25	0,87
10,0	8600		22	1,08	23	0,79
9,0	7740		20	0,97	21	0,71
8,0	6880		19	0,87	20	0,64
7,0	6020		17	0,76	13	0,56
6,0	5160		14	0,66	11	0,48
5,0	4300		10	0,55	10	0,41
4,0	3440	5	0,44	7	0,33	
3,0	2580	2	0,34	3	0,25	
2,8	2408	1	0,31	1	0,23	

4.2 COMBUSTION PARAMETERS

Combustion parameters: measuring conditions of useful efficiency (flow temperature/return temperature= 80 / 60 °C), ambient temperature reference = 15°C.

Victrix Zeus Superior 25

Gas type		G20	G31
Supply pressure	mbar (mm H ₂ O)	20 (204)	31 (377)
Gas nozzle diameter	mm	5	5
Flue flow rate at D.H.W. nominal heat output	kg/h (g/s)	43 (12.08)	43 (11.81)
Flue flow rate at heating nominal heat output	kg/h (g/s)	35 (9.71)	33 (9.18)
Flue flow rate at min heat output	kg/h (g/s)	4 (1.16)	4 (1.18)
CO, to nominal Q.	%	8.8 (±0,2)	10.3 (±0,2)
CO, to ignition Q.	%	8.8 (±0,2)	9.9 (±0,2)
CO, to minimum Q.	%	8.8 (±0,2)	9.9 (±0,2)
CO with 0% O ₂ at Nom./Min. Q.	ppm	155 / 5	215 / 6
NO _x with 0% O ₂ at Nom./Min. Q.	mg/kWh	31 / 21	53 / 23
Flue temperature at nominal output	°C	70	71
Flue temperature at minimum output	°C	60	53
Max air combustion temperature	°C	50	50

Intake / exhaust available head with Min	Intake / exhaust available head with Med	Intake / exhaust available head with Max
Pa	Pa	Pa
48	112	151

Victrix Zeus Superior 30

Gas type		G20	G31
Supply pressure	mbar (mm H ₂ O)	20 (204)	31 (377)
Gas nozzle diameter	mm	5.7	5.7
Flue flow rate at D.H.W. nominal heat output	kg/h (g/s)	52 (14.43)	50 (13.86)
Flue flow rate at heating nominal heat output	kg/h (g/s)	49 (13.55)	47 (13.02)
Flue flow rate at min heat output	kg/h (g/s)	5 (1.38)	5 (1.35)
CO, to nominal Q.	%	8.8 (±0,2)	10.5 (±0,2)
CO, to ignition Q.	%	8.8 (±0,2)	10.3 (±0,2)
CO, to minimum Q.	%	8.8 (±0,2)	10.3 (±0,2)
CO with 0% O ₂ at Nom./Min. Q.	ppm	134 / 3	233 / 3
NO _x with 0% O ₂ at Nom./Min. Q.	mg/kWh	22 / 15	41 / 25
Flue temperature at nominal output	°C	44	41
Flue temperature at minimum output	°C	47	42
Max air combustion temperature	°C	50	50

Intake / exhaust available head with Min	Intake / exhaust available head with Med	Intake / exhaust available head with Max
Pa	Pa	Pa
76	155	233

INSTALLER

USER

MAINTENANCE TECHNICIAN

TECHNICAL DATA

Victrix Zeus Superior 35

Gas type		G20	G31
Supply pressure	mbar (mm H ₂ O)	20 (204)	31 (377)
Gas nozzle diameter	mm	5.7	5.7
Flue flow rate at D.H.W. nominal heat output	kg/h (g/s)	59 (16.25)	57 (15.89)
Flue flow rate at heating nominal heat output	kg/h (g/s)	49 (13.55)	47 (13.02)
Flue flow rate at min heat output	kg/h (g/s)	5 (1.38)	5 (1.35)
CO ₂ to nominal Q.	%	8.8 (±0,2)	10.3 (±0,2)
CO ₂ to ignition Q.	%	8.8 (±0,2)	10.3 (±0,2)
CO ₂ to minimum Q.	%	8.8 (±0,2)	10.3 (±0,2)
CO with 0% O ₂ at Nom./Min. Q.	ppm	141 / 3	227 / 3
NO _x with 0% O ₂ at Nom./Min. Q.	mg/kWh	22 / 15	34 / 25
Flue temperature at nominal output	°C	44	41
Flue temperature at minimum output	°C	47	42
Max air combustion temperature	°C	50	50

Intake/ exhaust available head with Min	Intake/ exhaust available head with Med	Intake/ exhaust available head with Max
Pa	Pa	Pa
97	197	295

4.3 TECHNICAL DATA TABLE

		Victrix Zeus Superior 25	Victrix Zeus Superior 30	Victrix Zeus Superior 35
Domestic hot water nominal heat input	kW (kcal/h)	25.9 (22280)	30.9 (26598)	34.8 (29967)
Central heating nominal heat input	kW (kcal/h)	20.8 (17909)	29 (24976)	
Minimum heat input	kW (kcal/h)	2.5 (2143)	3 (2554)	
Domestic hot water nominal heat output (useful)	kW (kcal/h)	25 (21500)	30 (25800)	33.8 (29068)
Central heating nominal heat output (useful)	kW (kcal/h)	20.2 (17372)	28.2 (24252)	
Minimum heat output (useful)	kW (kcal/h)	2.3 (2012)	2.8 (2408)	
*Effective thermal efficiency 80/60 Nom./Min.	%	97/95.4	97.1/94.3	
*Effective thermal efficiency 50/30 Nom./Min.	%	105.1/105.7	105.4/103.7	
*Effective thermal efficiency 40/30 Nom./Min.	%	107.1/108,8	106.8/108,0	
Casing losses with burner On/Off (80-60°C)	%	0,38/1,40	0,57/1,40	0,51/1,40
Chimney losses with burner On/Off (80-60°C)	%	0,01/2,10	0,01/1,60	
Central heating circuit max. operating pressure	bar (MPa)	3,0 (0,30)		
Maximum heating temperature	°C	90		
Adjustable central heating temperature (min. operating field)	°C	20		
Adjustable central heating temperature (max operating field)	°C	85		
System expansion vessel total volume	l	5.8	7.1	
Expansion vessel pre-charged pressure	bar (MPa)	1,0 (0,10)		
Appliance water content	l	4.7	7.3	
Head available with 1000l/h flow rate	kPa (mH ₂ O)	1,03 (mca/kPa)	1,2 (mca/kPa)	
Hot water production useful heat output	kW (kcal/h)	25 (21500)	30 (25800)	33.8 (29068)
Domestic hot water adjustable temperature	°C	10-60		
Domestic hot water circuit min. pressure (dynamic)	bar (MPa)	0,6 (0,06)		
Domestic hot water circuit max. operating pressure	bar (MPa)	8,0 (0,80)		
Flow rate capacity in continuous duty (ΔT 30°C)	l/min	12.4	15	16.9
Weight of full boiler	kg	119	121.9	
Weight of empty boiler	kg	63.9	64.2	
Electrical connection	V/Hz	230/50		
Nominal power absorption	A	0.7	0.8	1
Installed electric power	W	95	110	130
Pump absorbed power	W	45	57	59
EEL value	-	≤0.20 - Det. 3		
Fan power absorbed power	W	40	42	68
Equipment electrical system protection	-	IPX5D		
Max temperature of combustion products	°C	75		
Max. flue overheating temperature	°C	120		
Ambient operating temperature range	°C	0 ÷ 40		
Ambient operating temperature range with optional antifreeze kit	°C	-15 ÷ 40		
NO _x class	-	6		
Weighted NO _x	mg/kWh	23	21	
Weighted CO	mg/kWh	15	16	
**Type of appliance	-	C13-C13x-C33-C33x-C43-C43x-C53-C53x-C63-C63x-C83-C83x-C93-C93x-C(10)3-C(12)3-C(15)3-C(10)3x-C(12)3x-C(15)3x-B23p-B33-B53p		

Category	-	II2H3P - I3P
----------	---	--------------

* The efficiency values refer to the lower calorific value.

The data relating to domestic hot water performance refer to a dynamic inlet pressure of 2 bar and an inlet temperature of 15°C; the values are measured immediately at the boiler outlet, considering that to obtain the data declared, mixing with cold water is required.

The weighted NO_x value refer to the net calorific value.

** For type C63 it is forbidden to install the appliance as it came out of the factory, in configurations that require shared flues in positive pressure.

INSTALLER

USER

MAINTENANCE TECHNICIAN

TECHNICAL DATA

4.4 KEY FOR DATA NAMEPLATE

Md		Cod. Md		
Sr N°	CHK	Cod. PIN		
Type				
Qnw/Qn min.	Qnw/Qn max.	Pn min.	Pn max.	
PMS	PMW	D	TM	
NOx Class				
				CONDENSING

69



The technical data is provided on the data nameplate on the boiler.

	ENG
Md	Model
Cod. Md	Model code
Sr N°	Serial Number
CHK	Check
Cod. PIN	PIN code
Type	Type of installation (ref. CENTR 1749)
Qnw min.	Minimum DHW heat input
Qn min.	Central heating minimum heat input
Qnw max.	DHW maximum heat input
Qn max.	Central heating maximum heat input
Pn min.	Minimum heat output
Pn max.	Maximum heat output
PMS	Maximum system pressure
PMW	Maximum domestic hot water pressure
D	Specific flow rate
TM	Maximum operating temperature
NOx Class	NOx Class
CONDENSING	Condensing boiler

4.5 TECHNICAL PARAMETERS FOR COMBINATION BOILERS (IN COMPLIANCE WITH REGULATION 813/2013)

The efficiencies and NO_x values in the following tables refer to the gross calorific value.

Model/s:				Victrix Zeus Superior 25				
Condensing Boilers:				SI				
Low temperature boiler:				NO				
Boiler type B1:				NO				
Co-generation appliance for central heating:				NO		Fitted with supplementary heating system:		NO
Mixed heating appliance:				SI				
Element	Symbol	Value	Unit	Element	Symbol	Value	Unit	
Nominal heat output	P_n	20	kW	Seasonal energy efficiency of central heating	η_s	94	%	
For central heating only and combination boilers: useful heat output				For central heating only and combination boilers: useful efficiency				
At nominal heat output in high temperature mode (*)	P_4	20,2	kW	At nominal heat output in high temperature mode (*)	η_4	87,7	%	
At 30% of nominal heat output in a low temperature mode (**)	P_1	6,9	kW	At 30% of nominal heat output in a low temperature mode (**)	η_1	99,0	%	
Auxiliary electricity consumption				Other items				
At full load	el_{max}	0,021	kW	Heat loss in standby	P_{stby}	0,058	kW	
At partial load	el_{min}	0,015	kW	Ignition burner energy consumption	P_{ign}	0,000	kW	
In standby mode	P_{SB}	0,005	kW	Emissions of nitrogen oxides	NO_x	21	mg/kWh	
For mixed central heating appliances								
Stated load profile	XL			Domestic hot water production efficiency	η_{WH}	80	%	
Daily electrical power consumption	Q_{elec}	0,234	kWh	Daily gas consumption	Q_{fuel}	24,651	kWh	
Contact information	IMMERGASS.p.A. VIA CISA LIGURE, 95 - 42041 BRESCELLO (RE) ITALY							
(*) High temperature mode means 60°C on return and 80°C on flow.								
(**) Low temperature mode for condensation Boilers means 30°C, for low temperature boilers 37°C and for other appliances 50°C of return temperature.								

INSTALLER

USER

MAINTENANCE TECHNICIAN

TECHNICAL DATA

Model/s:				Victrix Zeus Superior 30				
Condensing Boilers:				SI				
Low temperature boiler:				NO				
Boiler type B1:				NO				
Co-generation appliance for central heating:				NO		Fitted with supplementary heating system:		NO
Mixed heating appliance:				SI				
Element	Symbol	Value	Unit	Element	Symbol	Value	Unit	
Nominal heat output	P_n	28	kW	Seasonal energy efficiency of central heating	η_s	94	%	
For central heating only and combination boilers: useful heat output				For central heating only and combination boilers: useful efficiency				
At nominal heat output in high temperature mode (*)	P_4	28,2	kW	At nominal heat output in high temperature mode (*)	η_4	87,6	%	
At 30% of nominal heat output in a low temperature mode (**)	P_1	9,5	kW	At 30% of nominal heat output in a low temperature mode (**)	η_1	98,8	%	
Auxiliary electricity consumption				Other items				
At full load	$e_{l_{max}}$	0,020	kW	Heat loss in standby	P_{stby}	0,088	kW	
At partial load	$e_{l_{min}}$	0,015	kW	Ignition burner energy consumption	P_{ign}	0,000	kW	
In standby mode	P_{SB}	0,005	kW	Emissions of nitrogen oxides	NO_x	18	mg/kWh	
For mixed central heating appliances								
Stated load profile	XL			Domestic hot water production efficiency	η_{WH}	80	%	
Daily electrical power consumption	Q_{elec}	0,243	kWh	Daily gas consumption	Q_{fuel}	24,484	kWh	
Contact information	IMMERGASS.p.A. VIA CISA LIGURE, 95 - 42041 BRESCELLO (RE) ITALY							
(*) High temperature mode means 60°C on return and 80°C on flow.								
(**) Low temperature mode for condensation Boilers means 30°C, for low temperature boilers 37°C and for other appliances 50°C of return temperature.								

Model/s:				Victrix Zeus Superior 35				
Condensing Boilers:				SI				
Low temperature boiler:				NO				
Boiler type B1:				NO				
Co-generation appliance for central heating:				NO		Fitted with supplementary heating system:		NO
Mixed heating appliance:				SI				
Element	Symbol	Value	Unit	Element	Symbol	Value	Unit	
Nominal heat output	P_n	28	kW	Seasonal energy efficiency of central heating	η_s	94	%	
For central heating only and combination boilers: useful heat output				For central heating only and combination boilers: useful efficiency				
At nominal heat output in high temperature mode (*)	P_4	28,2	kW	At nominal heat output in high temperature mode (*)	η_4	87,6	%	
At 30% of nominal heat output in a low temperature mode (**)	P_1	9,5	kW	At 30% of nominal heat output in a low temperature mode (**)	η_1	98,8	%	
Auxiliary electricity consumption				Other items				
At full load	el_{max}	0,020	kW	Heat loss in standby	P_{stby}	0,088	kW	
At partial load	el_{min}	0,015	kW	Ignition burner energy consumption	P_{ign}	0,000	kW	
In standby mode	P_{SB}	0,005	kW	Emissions of nitrogen oxides	NO_x	18	mg/kWh	
For mixed central heating appliances								
Stated load profile	XL			Domestic hot water production efficiency	η_{WH}	80	%	
Daily electrical power consumption	Q_{elec}	0,244	kWh	Daily gas consumption	Q_{fuel}	24,507	kWh	
Contact information	IMMERGASS.p.A. VIA CISA LIGURE, 95 - 42041 BRESCELLO (RE) ITALY							
(*) High temperature mode means 60°C on return and 80°C on flow.								
(**) Low temperature mode for condensation Boilers means 30°C, for low temperature boilers 37°C and for other appliances 50°C of return temperature.								

INSTALLER

USER

MAINTENANCE TECHNICIAN

TECHNICAL DATA

4.6 PRODUCT FICHE (IN COMPLIANCE WITH REGULATION 811/2013)

Victrix Zeus Superior 25

INSTALLER

USER

MAINTENANCE TECHNICIAN

TECHNICAL DATA

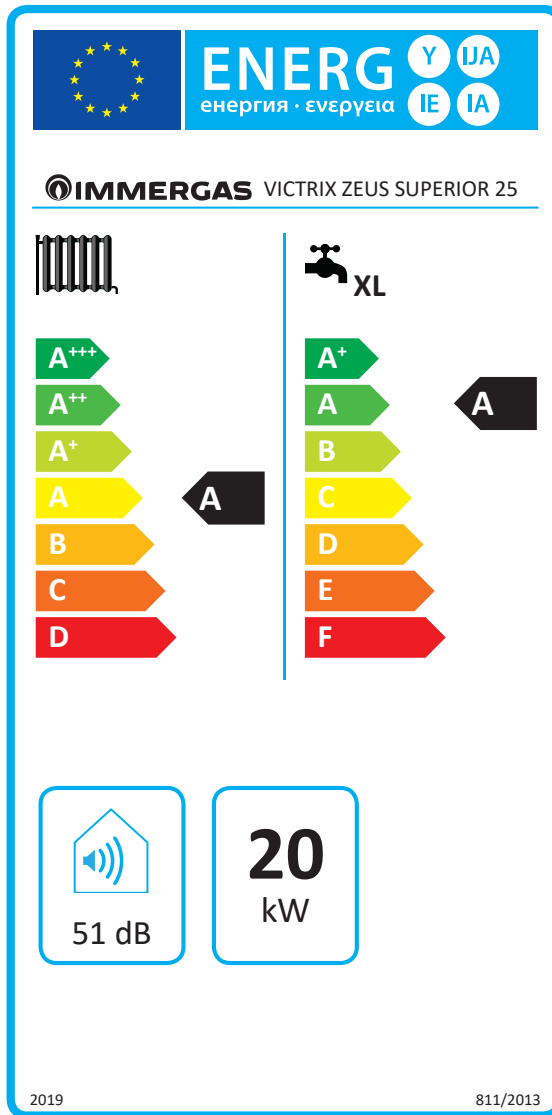

70

Parameter	value
Annual energy consumption for the central heating mode (QHE)	34,7 GJ
Annual electricity consumption for the domestic hot water function (AEC)	51 kWh
Annual fuel consumption for the domestic hot water function (AFC)	20 GJ
Seasonal space heating energy efficiency (η_s)	94 %
Water heating energy efficiency (η_{wh})	80 %

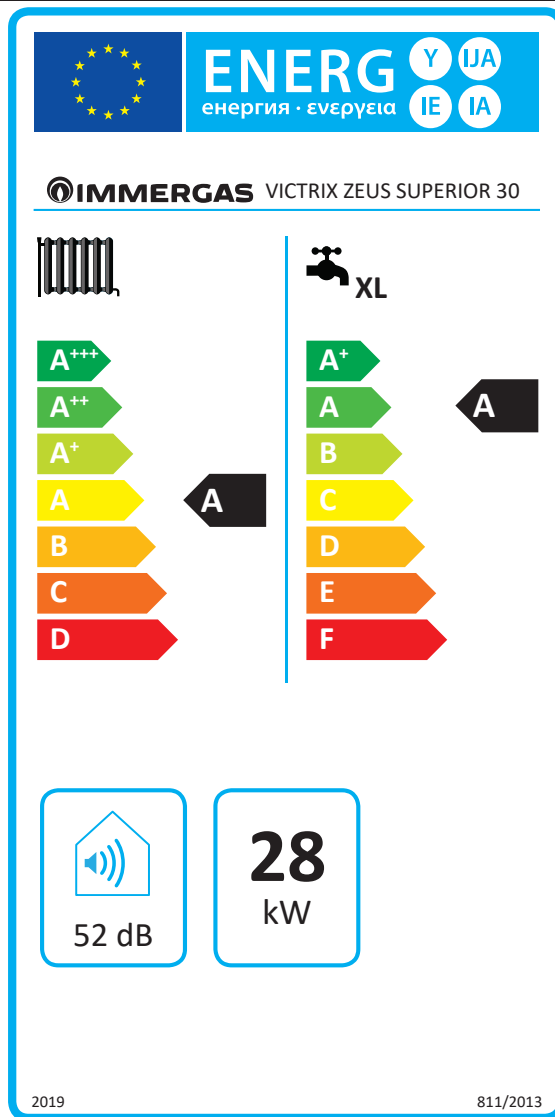

71

Parameter	value
Annual energy consumption for the central heating mode (QHE)	47,7 GJ
Annual electricity consumption for the domestic hot water function (AEC)	53 kWh
Annual fuel consumption for the domestic hot water function (AFC)	19 GJ
Seasonal space heating energy efficiency (η_s)	94 %
Water heating energy efficiency (η_{wh})	80 %

INSTALLER

USER

MAINTENANCE TECHNICIAN

TECHNICAL DATA

Victrix Zeus Superior 35

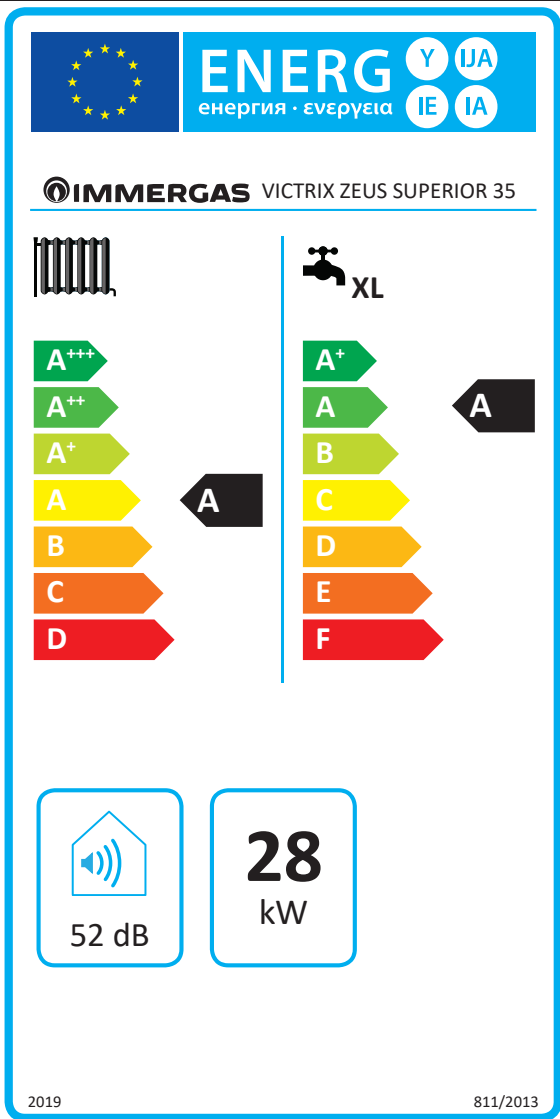

Parameter	value
Annual energy consumption for the central heating mode (QHE)	47,7 GJ
Annual electricity consumption for the domestic hot water function (AEC)	54 kWh
Annual fuel consumption for the domestic hot water function (AFC)	19 GJ
Seasonal space heating energy efficiency (η_s)	94 %
Water heating energy efficiency (η_{wh})	80 %

For proper installation of the appliance refer to chapter 1 of this booklet (for the installer) and current installation regulations. For proper maintenance refer to chapter 3 of this booklet (for the maintenance technician) and adhere to the frequencies and methods set out herein.

4.7 PARAMETERS FOR FILLING IN THE PACKAGE FICHE

In case you should wish to install an assembly, starting from this boiler, use the assembly charts in (Fig. 74 and 76). To complete it properly, fill the relevant spaces as shown in the assembly chart facsimile (Fig. 73) and (75) with the values shown in tables "Parameters for filling in the assembly chart" and "Parameters for filling in the D.H.W. package assembly chart".

The remaining values must be obtained from the technical data sheets of the products used to make up the assembly (e.g. solar devices, integration heat pumps, temperature controllers).

Use board (Fig. 74) for "assemblies" related to the central heating mode (e.g.: boiler + temperature controller).

Use board (Fig. 76) for "assemblies" related to the domestic hot water function (e.g.: boiler + solar thermal system).

Facsimile for filling in the package fiche for room central heating systems.

Seasonal central heating energy efficiency of the boiler		1	<input type="text" value="'I'"/>	%																														
Temperature control From temperature control board	Class I = 1 %, Class II = 2 %, Class III = 1.5 %, Class IV = 2 %, Class V = 3 %, Class VI = 4 %, Class VII = 3.5 %, Class VIII = 5 %	2	+ <input type="text"/>	%																														
Supplementary boiler From boiler board	Seasonal central heating energy efficiency of the room (%)	3	(<input type="text"/> - 'I') x 0.1 = ± <input type="text"/>	%																														
Solar contribution From the board of the solar device	Dimensions of the manifold (in m ²) Volume of the tank (in m ³) Efficiency of the manifold (in %)	Classification of the tank A* = 0.95, A = 0.91, B = 0.86, C = 0.83, D-G = 0.81	4	('III' x <input type="text"/> + 'IV' x <input type="text"/>) x (0.9 x (<input type="text"/> / 100) x <input type="text"/> = + <input type="text"/>	%																													
Supplementary heat pump From the heat pump board	Seasonal central heating energy efficiency of the room (%)	5	(<input type="text"/> - 'I') x 'II' = + <input type="text"/>	%																														
Solar contribution and supplementary heat pump Select the lowest value	0.5 x 4 <input type="text"/> O 0.5 x 5 <input type="text"/>	6	= - <input type="text"/>	%																														
Seasonal central heating energy efficiency of the set		7	<input type="text"/>	%																														
Seasonal central heating energy efficiency class of the set	<table border="1"> <tr> <td><input type="checkbox"/></td><td><input type="checkbox"/></td><td><input type="checkbox"/></td><td><input type="checkbox"/></td><td><input type="checkbox"/></td><td><input type="checkbox"/></td><td><input type="checkbox"/></td><td><input type="checkbox"/></td><td><input type="checkbox"/></td><td><input type="checkbox"/></td> </tr> <tr> <td>G</td><td>F</td><td>E</td><td>D</td><td>C</td><td>B</td><td>A</td><td>A⁺</td><td>A⁺⁺</td><td>A⁺⁺⁺</td> </tr> <tr> <td>< 30 %</td><td>≥ 30 %</td><td>≥ 34 %</td><td>≥ 36 %</td><td>≥ 75 %</td><td>≥ 82 %</td><td>≥ 90 %</td><td>≥ 98 %</td><td>≥ 125 %</td><td>≥ 150 %</td> </tr> </table>				<input type="checkbox"/>	<input type="checkbox"/>	<input type="checkbox"/>	<input type="checkbox"/>	<input type="checkbox"/>	<input type="checkbox"/>	<input type="checkbox"/>	<input type="checkbox"/>	<input type="checkbox"/>	<input type="checkbox"/>	G	F	E	D	C	B	A	A⁺	A⁺⁺	A⁺⁺⁺	< 30 %	≥ 30 %	≥ 34 %	≥ 36 %	≥ 75 %	≥ 82 %	≥ 90 %	≥ 98 %	≥ 125 %	≥ 150 %
<input type="checkbox"/>	<input type="checkbox"/>	<input type="checkbox"/>	<input type="checkbox"/>	<input type="checkbox"/>	<input type="checkbox"/>	<input type="checkbox"/>	<input type="checkbox"/>	<input type="checkbox"/>	<input type="checkbox"/>																									
G	F	E	D	C	B	A	A⁺	A⁺⁺	A⁺⁺⁺																									
< 30 %	≥ 30 %	≥ 34 %	≥ 36 %	≥ 75 %	≥ 82 %	≥ 90 %	≥ 98 %	≥ 125 %	≥ 150 %																									
Boiler and supplementary heat pump installed with low temperature heat emitters at 35 °C? From the board of the heat pump	7 <input type="text"/>		+ (50 x 'II') = <input type="text"/>	%																														
The energy efficiency of the set of products indicated in this sheet may not reflect the actual energy efficiency after installation since such efficiency is affected by additional factors, such as the heat loss in the distribution system and the size of the products compared to the size and features of the building.																																		

INSTALLER

USER

MAINTENANCE TECHNICIAN

TECHNICAL DATA

Parameters for filling in the assembly chart

Parameter	Victrix Zeus Superior 25	Victrix Zeus Superior 30	Victrix Zeus Superior 35
"I"		94	
"II"		*	
"III"		0.95	
"IV"		0.37	

* to be established by means of table 5 of Regulation 811/2013 in case of "assembly" including a heat pump to integrate the boiler. In this case the boiler must be considered as the main appliance of the assembly.

Room central heating system package fiche.

Seasonal central heating energy efficiency of the boiler 1 %

Temperature control
From temperature control board

Class I = 1 %, Class II = 2 %,
 Class III = 1.5 %, Class IV = 2 %,
 Class V = 3 %, Class VI = 4 %,
 Class VII = 3.5 %, Class VIII = 5 %

2 + %

Supplementary boiler
From boiler board

Seasonal central heating energy efficiency of the room (%)

$$(\text{ } - \text{ }) \times 0.1 = \pm \text{ } \%$$
3

Solar contribution
From the board of the solar device

Dimensions of the manifold (in m²)

Volume of the tank (in m³)

Efficiency of the manifold (in %)

Classification of the tank
A* = 0.95, A = 0.91,
B = 0.86, C = 0.83,
D-G = 0.81

$$(\text{ } \times \text{ } + \text{ } \times \text{ }) \times (0.9 \times (\text{ } / 100) \times \text{ } = + \text{ } \%$$
4

Supplementary heat pump
From the heat pump board

Seasonal central heating energy efficiency (in %)

$$(\text{ } - \text{ }) \times \text{ } = + \text{ } \%$$
5

Solar contribution and supplementary heat pump

Select the lowest value

$$0.5 \times \text{ } \text{ O } 0.5 \times \text{ } = - \text{ } \%$$
6

Seasonal central heating energy efficiency of the set 7 %

Seasonal central heating energy efficiency class of the set

<input type="checkbox"/>	<input type="checkbox"/>	<input type="checkbox"/>	<input type="checkbox"/>	<input type="checkbox"/>	<input type="checkbox"/>	<input type="checkbox"/>	<input type="checkbox"/>	<input type="checkbox"/>	<input type="checkbox"/>
G	F	E	D	C	B	A	A⁺	A⁺⁺	A⁺⁺⁺
< 30 %	≥ 30 %	≥ 34 %	≥ 36 %	≥ 75 %	≥ 82 %	≥ 90 %	≥ 98 %	≥ 125 %	≥ 150 %

Boiler and supplementary heat pump installed with low temperature heat emitters at 35 °C?

From the board of the heat pump

$$\text{ } + (50 \times \text{ }) = \text{ } \%$$
7

The energy efficiency of the set of products indicated in this sheet may not reflect the actual energy efficiency after installation since such efficiency is affected by additional factors, such as the heat loss in the distribution system and the size of the products compared to the size and features of the building.



Facsimile for filling in the domestic hot water production system package fiche

Water heating energy efficiency of combination boiler

¹
 %

Stated load profile:

Solar contribution

From the board of the solar device

Auxiliary electricity

$$(1.1 \times \text{'I'} - 10\%) \times \text{'II'} - \text{'III'} - \text{'I'} = + \text{} \%$$

Water heating energy efficiency of the assembly in average climate conditions

³
 %

Water heating energy efficiency class of the assembly in average climate conditions

	<input type="checkbox"/>	<input type="checkbox"/>	<input type="checkbox"/>	<input type="checkbox"/>	<input type="checkbox"/>	<input type="checkbox"/>	<input type="checkbox"/>	<input type="checkbox"/>	<input type="checkbox"/>	<input type="checkbox"/>
	G	F	E	D	C	B	A	A⁺	A⁺⁺	A⁺⁺⁺
<input type="checkbox"/> M	< 27 %	≥ 27 %	≥ 30 %	≥ 33 %	≥ 36 %	≥ 39 %	≥ 65 %	≥ 100 %	≥ 130 %	≥ 163 %
<input type="checkbox"/> L	< 27 %	≥ 27 %	≥ 30 %	≥ 34 %	≥ 37 %	≥ 50 %	≥ 75 %	≥ 115 %	≥ 150 %	≥ 188 %
<input type="checkbox"/> XL	< 27 %	≥ 27 %	≥ 30 %	≥ 35 %	≥ 38 %	≥ 55 %	≥ 80 %	≥ 123 %	≥ 160 %	≥ 200 %
<input type="checkbox"/> XXL	< 28 %	≥ 28 %	≥ 32 %	≥ 36 %	≥ 40 %	≥ 60 %	≥ 85 %	≥ 131 %	≥ 170 %	≥ 213 %

Water heating energy efficiency class in colder and hotter climate conditions

Colder: ³ - 0.2 x ² = %

Hotter: ³ + 0.4 x ² = %

The energy efficiency of the set of products indicated in this sheet may not reflect the actual energy efficiency after installation since such efficiency is affected by additional factors, such as the heat loss in the distribution system and the size of the products compared to the size and features of the building.

INSTALLER

USER

MAINTENANCE TECHNICIAN

TECHNICAL DATA

Parameters for filling in the DHW package fiche

Parameter	Victrix Zeus Superior 25	Victrix Zeus Superior 30	Victrix Zeus Superior 35
"I"		80	
"II"		*	
"III"		*	

* to be determined according to Regulation 811/2013 and transient calculation methods as per Notice of the European Community no. 207/2014.

Domestic hot water production system package fiche.

Water heating energy efficiency of combination boiler ① %

Stated load profile:

Solar contribution
From the board of the solar device

Auxiliary electricity
↓

(1.1 x - 10 %) x - - = + ② %

Water heating energy efficiency of the assembly in average climate conditions ③ %

Water heating energy efficiency class of the assembly in average climate conditions

<input type="checkbox"/>	<input type="checkbox"/>	<input type="checkbox"/>	<input type="checkbox"/>	<input type="checkbox"/>	<input type="checkbox"/>	<input type="checkbox"/>	<input type="checkbox"/>	<input type="checkbox"/>	<input type="checkbox"/>	
	G	F	E	D	C	B	A	A⁺	A⁺⁺	A⁺⁺⁺
<input type="checkbox"/> M	< 27 %	≥ 27 %	≥ 30 %	≥ 33 %	≥ 36 %	≥ 39 %	≥ 65 %	≥ 100 %	≥ 130 %	≥ 163 %
<input type="checkbox"/> L	< 27 %	≥ 27 %	≥ 30 %	≥ 34 %	≥ 37 %	≥ 50 %	≥ 75 %	≥ 115 %	≥ 150 %	≥ 188 %
<input type="checkbox"/> XL	< 27 %	≥ 27 %	≥ 30 %	≥ 35 %	≥ 38 %	≥ 55 %	≥ 80 %	≥ 123 %	≥ 160 %	≥ 200 %
<input type="checkbox"/> XXL	< 28 %	≥ 28 %	≥ 32 %	≥ 36 %	≥ 40 %	≥ 60 %	≥ 85 %	≥ 131 %	≥ 170 %	≥ 213 %

Water heating energy efficiency class in colder and hotter climate conditions

Colder: ③ - 0.2 x ② = ④ %

Hotter: ③ + 0.4 x ② = ④ %

The energy efficiency of the set of products indicated in this sheet may not reflect the actual energy efficiency after installation since such efficiency is affected by additional factors, such as the heat loss in the distribution system and the size of the products compared to the size and features of the building.





This instruction booklet is made of ecological paper.

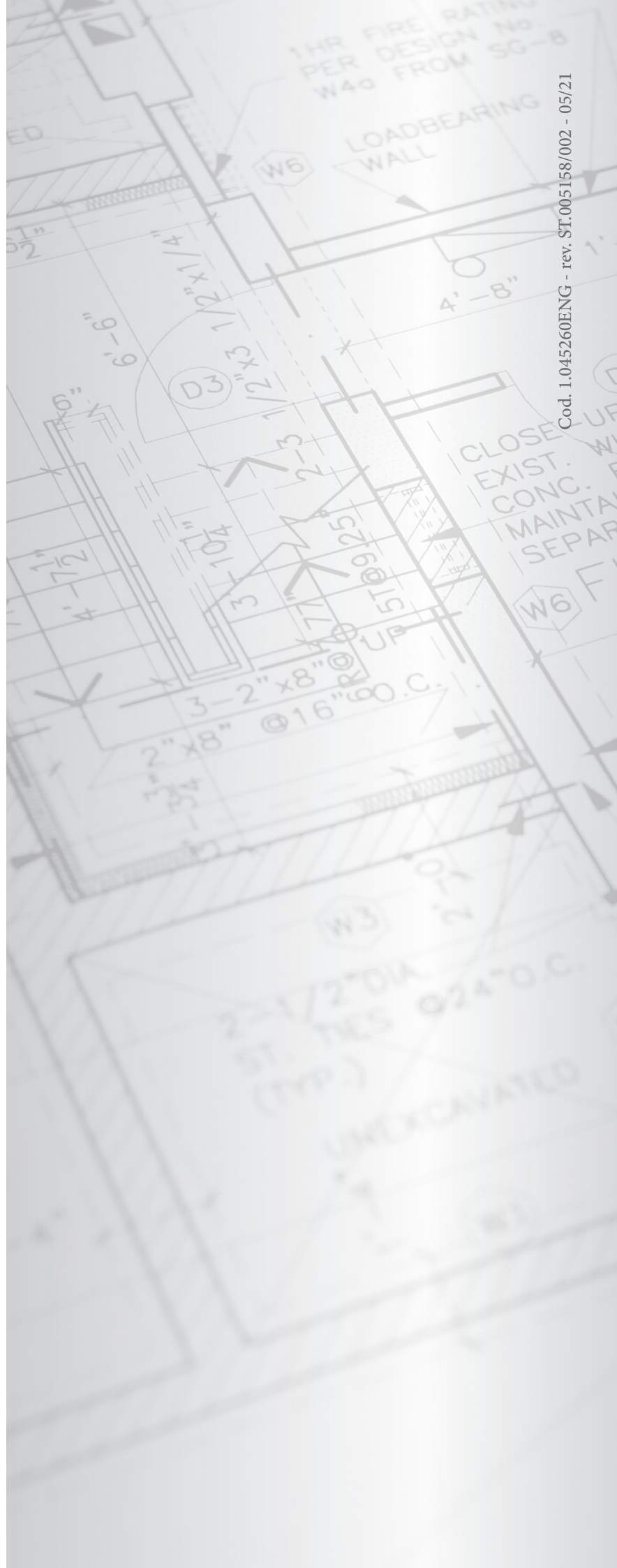

Cod. 1.045260ENG - rev. ST.005158/002 - 05/21

immergas.com

Immergas S.p.A.
42041 Brescello (RE) - Italy
Tel. 0522.689011
Fax 0522.680617



IMMERGAS
IMMERGAS SPA - ITALY
CERTIFIED COMPANY
UNI EN ISO 9001:2015

Design, manufacture and post-sale assistance of gas boilers, gas water heaters and related accessories